

**(CORRECTED)**  
**Ordinance (2011) 940ZC662**

**AN ORDINANCE TO AMEND THE ZONING ORDINANCE OF THE CITY OF RALEIGH WHICH INCLUDES THE ZONING DISTRICT MAP BE IT ORDAINED BY THE CITY COUNCIL OF THE CITY OF RALEIGH**

**Section 1.** That Section 10 of the City of Raleigh Code, which includes the Zoning District Map, be and the same if hereby amended as follows:

**Z-9-11 Conditional Use – Creedmoor Road** - located on the east side, southeast of its intersection with Crabtree Valley, being Wake County PINs 0796302996, 0796308642, and 0796314150. Approximately 11.74 acres to be rezoned from Shopping Center (0.81 acre) and SC with (PDD) Planned Development District and (PBOD) Pedestrian Business Overlay District (10.93 acres) to SC CUD with PBOD (8.126 acres), and SC CUD (3.613 acres).

**Conditions Dated: 8/15/11**

**Narrative or conditions being requested:**

For the purposes of the following conditions, Property” shall refer to tax parcels (PINs) 0796-30-2996, 0796-30-8642, and 0796-31-4150.

(a) The following uses shall be prohibited upon the Property: automotive service and repair facility; utility service and substation; emergency shelter Type A or Type B; landfill; manufacturing-custom; manufacturing-specialized; adult establishment; kennel/cattery; riding stable; correctional/penal facility; and outdoor stadium, outdoor theater or outdoor racetrack.

(b) With the exception of Hotel/Motel, an allowed use upon the Property, all uses developed upon the Property that are categorized as “Commercial” in the Schedule of Permitted Land Uses attached hereto as Exhibit C-1 shall not exceed 200,000 square feet floor area gross.

(c) All uses developed upon the Property that are characterized as Institution/Civic/Services or Office in the Schedule of Permitted Land Uses attached hereto as Exhibit C-1 shall not exceed 100,000 square feet floor area gross.

(d) Uses developed upon the Property that are characterized as Residential in the Schedule of Permitted Land Uses attached hereto as Exhibit C-1 shall not exceed 575 dwelling units.

**Ordinance (2011) 940ZC662**  
**September 6, 2011**

(e) Within fifteen (15) days following the approval of the form and substance of the restrictive covenant hereinafter mentioned by the City Attorney or his or her deputy, the owner of the Property shall cause to be recorded in the Wake County Registry a restrictive covenant that allocates allowable development upon the Property as provided in the foregoing conditions (b), (c), and (d) among all existing lots of record comprising the Property. Such restrictive covenant shall be submitted to the City Attorney within thirty (30) days following approval of this zoning case by the City Council and shall be approved by the City Attorney or his or her deputy prior to recordation. Such restrictive covenant shall provide that it shall become null and void and of no effect whatsoever in the event that a court enters a final judgment (not subject to appeal) declaring the rezoning resulting from the approval of this case invalid. The restrictive covenant and the allocation of development set forth therein may be amended from time to time following recordation. Any such amendment shall require the written concurrence of the owner(s) of all portions of the Property affected by the amendment and shall be at the sole discretion of such owner(s). Following recordation a copy of each amendment shall be mailed to the Planning Director at P.O. Box 590, Raleigh, NC. 27602.

(f) The land use or uses developed upon the Property shall be limited to a use or uses which when analyzed using the Trip Generation Manual published by the Institute of Transportation Engineers will generate no more than 12,947 daily vehicle trips with no more than 705 vehicle trips in the AM peak hour and no more than 934 vehicle trips in the PM peak hour.

(g) Upon development of Section 1 of the Property as shown on Exhibit B-1 of the Petition in this case, a means shall be provided for pedestrian connectivity from the then existing grade of Section 1 to the grade of Crabtree Valley Avenue as it is now located between the Property and Crabtree Valley Mall (PIN 0796-50-2569).

(h) The actual location of the “Crabtree Valley Mall Connector Road” shown on pages 4 and 16 of the Streetscape and Parking Plan in this case will be established at the time of site plan approval.

(i) Along the Creedmoor Road frontage of the Property, parking between the street right-of-way and the building(s) shall not exceed two rows of parking.

(j) Upon approval of a site plan or plans for the development of all or a portion of the Property, if requested by the City’s Transit Division, the owner shall dedicate a transit easement approved by the Raleigh City Attorney upon the respective site or sites of a size, nature and location acceptable to such Division and provide any improvements, such as a bench and/or shelter, specified by such Division that shall be in accordance with its standard policies. The owner shall dedicate up to three (3) transit easements upon the Property.

**Ordinance (2011) 940ZC662**  
**September 6, 2011**

(k) Upon development of Section 3 of the Property as shown on Exhibit B-1 of the Petition in this case, pedestrian connectivity shall be provided between such Section and the adjoining Section 2. With regard to sidewalks along public rights of way, the design of sidewalk sections and curb and sidewalk details for Section 3 shall be coordinated with such design for Sections 1 and 2, although to the extent allowed by the City's Ordinances, sidewalk widths may be reduced for Section 3. Plants planted along public rights of way in Section 3 shall be consistent with those utilized for such purpose in Sections 1 and 2.

**Ordinance (2011) 940ZC662  
September 6, 2011**

2-9-11

Exhibit B-1

Legal Descriptions of Sections 1, 2 and 3 are attached.

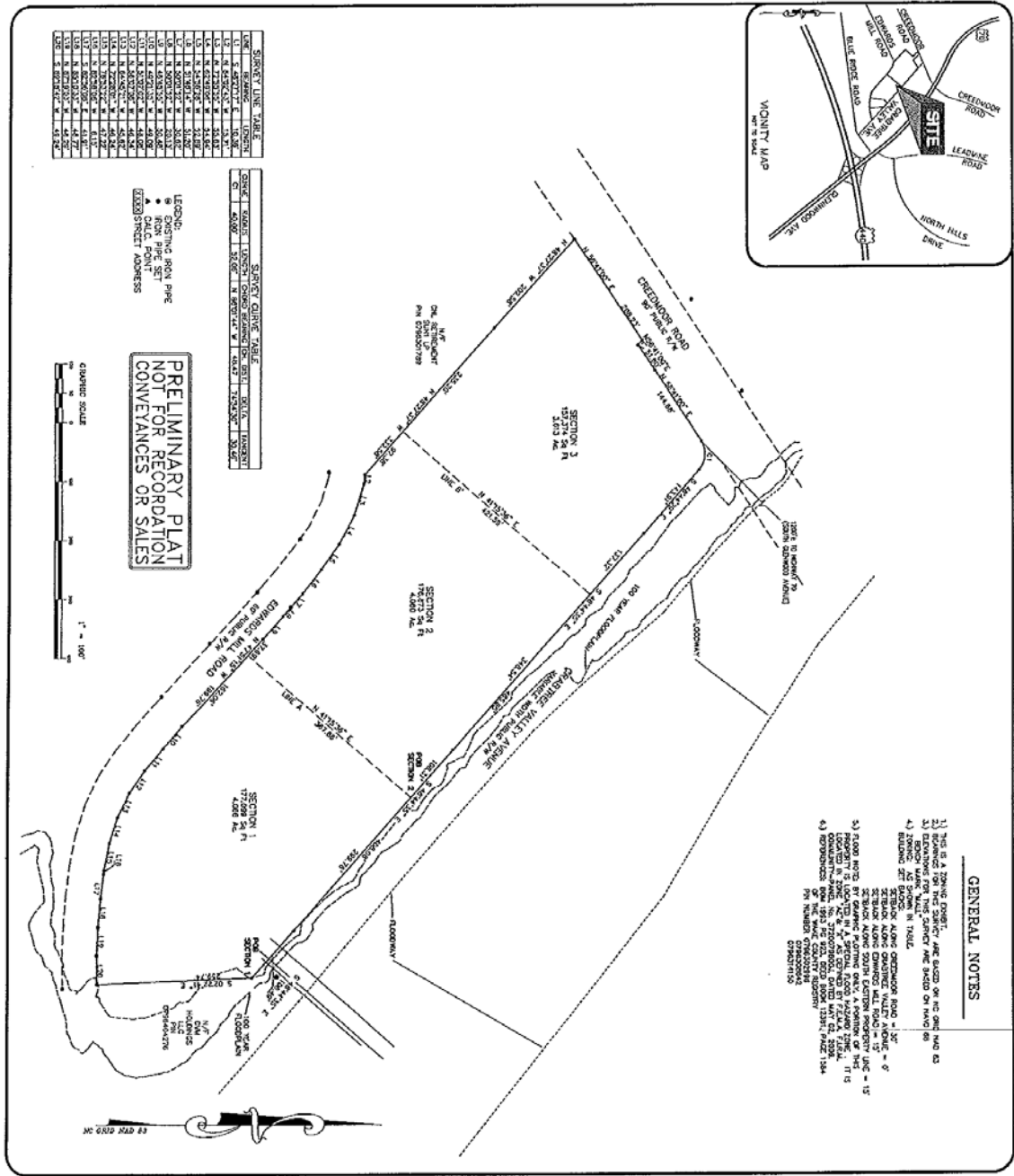

<p><b>McADAMS</b></p>	<p>ZONING EXHIBIT</p> <p><b>CRABTREE PLACE</b></p> <p>CITY OF RALEIGH, WAKE COUNTY, NORTH CAROLINA</p> <p>WEINCARTEN REALTY INVESTORS 9420 FORUM DRIVE SUITE 101 RALEIGH, NORTH CAROLINA</p>	<p>REVISIONS:</p> <table border="1" style="width: 100%; border-collapse: collapse;"> <tr><td> </td><td> </td></tr> <tr><td> </td><td> </td></tr> <tr><td> </td><td> </td></tr> <tr><td> </td><td> </td></tr> </table>									<p><b>THE JOHN R. McADAMS COMPANY, INC.</b></p> <p>ENGINEERS/PLANNERS/SURVEYORS</p> <p>RESEARCH TRIANGLE PARK, NC P.O. BOX 14005 ZIP 27709-4005 (919) 381-6000</p>

**Ordinance (2011) 940ZC662**  
**September 6, 2011**

2-9-11

PROPERTY DESCRIPTION SECTION 1

Beginning at an iron pipe at the intersection of the southern right of way of Crabtree Valley Avenue and the northern right of way of Edwards Mill Road, being the POINT OF BEGINNING; thence with the Northern right of way or Edwards Mill Road South 02°22'41" East, a distance of 259.74 feet to an iron pipe; thence South 89°18'42" West, a distance of 49.24 feet to an iron pipe; thence North 87°19'03" West, a distance of 48.29 feet to an iron pipe; thence North 85°10'33" West, a distance of 48.77 feet to an iron pipe; thence North 82°56'08" West, a distance of 41.91 feet to an iron pipe; thence continuing along said line, a distance of 6.15 feet to an iron pipe; thence North 78°53'22" West, a distance of 47.22 feet to an iron pipe; thence North 72°28'01" West, a distance of 46.24 feet to an iron pipe; thence North 64°45'21" West, a distance of 45.62 feet to an iron pipe; thence North 56°07'08" West, a distance of 46.34 feet to an iron pipe; thence North 51°07'02" West, a distance of 48.08 feet to an iron pipe; thence North 49°21'35" West, a distance of 49.09 feet to an iron pipe; thence North 47°51'15" West, a distance of 162.06 feet to a point; thence leaving said right of way North 41°15'36" East, a distance of 367.85 feet to a point on the southern right of way of Crabtree Valley Avenue; thence with said right of way South 48°44'35" East, a distance of 299.76 feet to an iron pipe; thence continuing along said line, a distance of 106.49 feet to an iron pipe, being the POINT OF BEGINNING, and containing 177,099 square feet or 4.066 acres, more or less .

**Ordinance (2011) 940ZC662**  
**September 6, 2011**

2-9-11

PROPERTY DESCRIPTION SECTION 2

Beginning at a point on the southern right of way of Crabtree Valley Avenue, said point being the POINT OF BEGINNING; thence leaving said right of way South 41°15'36" West, a distance of 367.85 feet to a point in the northern right of way of Edwards Mill Road; thence with said right of way North 47°51'15" West, a distance of 37.69 feet to an iron pipe; thence North 48°45'55" West, a distance of 50.48 feet to an iron pipe; thence North 50°01'52" West, a distance of 20.13 feet to an iron pipe; thence continuing along said line, a distance of 30.62 feet to an iron pipe; thence North 51°46'14" West, a distance of 51.20 feet to an iron pipe; thence North 54°56'28" West, a distance of 52.89 feet to an iron pipe; thence North 62°49'06" West, a distance of 54.94 feet to an iron pipe; thence North 72°55'55" West, a distance of 55.63 feet to an iron pipe; thence North 84°02'43" West, a distance of 15.71 feet to an iron pipe; thence North 48°27'37" West, a distance of 97.38 feet to an iron pipe; thence leaving said right of way North 41°15'36" East, a distance of 421.59 feet to a point in the southern right of way of Crabtree Valley Avenue; thence with said right of way South 48°44'35" East, a distance of 348.54 feet to an iron pipe; thence continuing along said line, a distance of 108.31 feet to a point, said point being the POINT OF BEGINNING, and containing 176,872 square feet or 4.060 acres, more or less .



2-9-11

§ 10-2071

RALBIGH CITY CODE

9/05

LAND USE	ZONING DISTRICTS																						
	RR	SP-R-5	R-8	RH	R-10	R-15	H-20	SP-R-30	R-30	CM	AP	BB	O&I-1	O&I-2	O&I-3	BC	SC	NC	SB	TD	F-1	F-2	
<b>RECREATION*</b>																							
<i>Accessory structures (fence, well, storage building)</i>	○	○	○	○	○	○	○	○	○	○	○	○	○	○	○	○	○	○	○	○	○	○	○
<i>Non-governmental</i>																							
<i>Not for profit</i>																							
<i>Accessories to single family dwelling units (e.g., swimming pool, basketball, pool, tennis court, horse stall)</i>	●	●	●	●	●	●	●	●	●	●	●	●	●	●	●	●	●	●	●	●	●	●	●
<i>Camp</i>	●	●	●	●	●	●	●	●	●	●	●	●	●	●	●	●	●	●	●	●	●	●	●
<i>Recreational use related to residential development other than a single family dwelling unit (e.g., swimming pool, play court, party and reception room, sauna)</i>	○	○	○	○	○	○	○	○	○	○	○	○	○	○	○	○	○	○	○	○	○	○	○
<i>Recreational use restricted to membership only - not for profit (e.g., golf course, swimming pool, play court)</i>	■	■	■	■	■	■	■	■	■	■	■	■	■	■	■	■	■	■	■	■	■	■	■
<i>Commercial:</i>																							
<i>Recreational use restricted to membership only - commercial (e.g., golf course, health club, swimming pool)</i>	○	○	○	○	○	○	○	○	○	○	○	○	○	○	○	○	○	○	○	○	○	○	○
<i>Recreational, indoor use - commercial (e.g., indoor arena/cosplay/theater, arcade, bowling alley, billiard parlor, dance hall, miniature golf)</i>	■	■	■	■	■	■	■	■	■	■	■	■	■	■	■	■	■	■	■	■	■	■	■
<i>Recreational, outdoor use - commercial (e.g., bathing cage, golf course, driving range)</i>	■	■	■	■	■	■	■	■	■	■	■	■	■	■	■	■	■	■	■	■	■	■	■
<i>Trailing stables</i>	■	■	■	■	■	■	■	■	■	■	■	■	■	■	■	■	■	■	■	■	■	■	■
<i>Table, range - indoor</i>	■	■	■	■	■	■	■	■	■	■	■	■	■	■	■	■	■	■	■	■	■	■	■
<i>Table range - outdoor</i>	■	■	■	■	■	■	■	■	■	■	■	■	■	■	■	■	■	■	■	■	■	■	■
<i>Recreational/indoor use - commercial (Ord. No. 3996-07-10-180, §§ 10-2-95.1-1996 Ord. No. 1888-07-10-181, Sections 504, 505-506)</i>	■	■	■	■	■	■	■	■	■	■	■	■	■	■	■	■	■	■	■	■	■	■	■

\*City Council Site Plan Approval shall be required for buildings eighty (80) feet in height or higher, which contain any occupiable room, as defined by the North Carolina State Building Code, or for uses located in the downtown area, as set forth in §(6-2122)(b)(4).



2-9-11

LAND USE	ZONING DISTRICTS																									
	HR	R-2	B-4	SP R-5	R-6	MN	R-10	R-15	R-20	SP R-30	R-30	GM	AP	RB	O&L-1	O&L-2	O&L-3	BC	SC	NB	Blue Zone	TD	L-1	L-2		
<b>RECREATION (continued)</b>																										
Non-governmental (continued)																										
Commercial (continued)																										
Outdoor: stadium / theater / amphitheatre / racetrack																										
250 seats or less																										
More than 250 seats																										
Governmental																										
Recreational use - governmental (e.g. park, greenway, athletic league field, swimming pool)																										
Indoor arena / coliseum / theater as a principal use or not part of a public park																										
Outdoor: stadium / theater / amphitheatre / racetrack																										
250 seats or less																										
More than 250 seats																										
Riding stable																										
Rifle range																										
Indoor (as part of a law enforcement training facility)																										
Indoor (other)																										
Outdoor																										
Temporary event																										
(Temporary event: Ord. No. 1989-286-TC-66, §C, TC-22-48, 12-7-89)																										
Editor's note: Ord. No. 1986-984-TC-120, §§ TC-22-45, adopted April 2, 1988, changed the definition of "Conservation Building" to "Conservation Management".																										

General Use  
 Conditional Use  
 Special Use (City Council)  
 Special Use (Board of Adjustment)  
 Size Plans Approval (City Council) required  
 Preliminary Size Plan Approval (Planning Comm. or City Council) may be required

2-9-11

§ 10-2071

RALEIGH CITY CODE

6/09

LAND USE	ZONING DISTRICTS																							
	RR	R-2	SP R-6	R-6	MH	R-10	R-15	R-20	SP R-30	R-30	CM	AB	RB	O-1-1	O-1-2	O-1-3	BC	SC	NB	BR	TD	L-1	L-2	
<b>RESIDENTIAL*</b>																								
Accessory Structures and Uses																								
Aboveground storage tanks (home consumption), deck, firepit, fountain, garden, gazebos (non-commercial), hot air balloon, (recreational), monument, open space, parking area, patio, swimming pool, tennis court, family day care, etc.																								
Fence, garage (not otherwise listed as a special use), storage building, well.																								
The storage of manufactured homes or mobile homes (unoccupied).																								
Dish antennae																								
Garage for 4 or more motorized vehicles accessory to a single family detached or duplex dwelling.																								
Cluster unit development																								
10 acres (minimum)																								
20 acres (minimum)																								
Congregate care structure or congregated living structure (senior citizen housing) (outside cluster unit development)																								
Fraternity house																								
Group housing (multiple apartment houses on campus) (outside cluster unit development)																								
Guest house (visitor lodging)																								
Life care community (senior citizen development) (outside cluster unit development)																								
Limited home business																								

General Use  
 Conditional Use  
 Special Use (City Council)  
 Special Use (Board of Adjustment)  
 Site Plan Approval (City Council) required  
 Preliminary Site Plan Approval (Planning Comm. or City Council) may be required  
 Contains any occupiable room, as defined by the North Carolina State Building Code, or for uses located in the downtown area as set forth in §10-2152.2(b)(4).

2-9-11

6/09

PLANNING AND DEVELOPMENT

§ 10-2071

LAND USE	ZONING DISTRICTS																					
	RR	R-2	R-4	SP R-6	SP R-8	MH	R-10	R-15	R-20	SP R-30	GM	AP	OR-1	OR-2	OR-3	BC	NB	BUS ZONE	TD	M1	L2	
<b>RESIDENTIAL (continued)</b>																						
<i>Manufactured home park</i>																						
<i>Manufactured home subdivision</i>																						
<i>Multi-family dwelling development (outside cluster zone/development)</i>																						
<i>Residential development sites: office or model home</i>																						
<i>Residence of a caretaker or watchman necessary to a permitted industrial use, rectory, parish house</i>																						
<i>Row houses</i>																						
<i>Rowing house, boarding house, lodging house or tourist home</i>																						
<i>Room rental in dwelling unit (lodger)</i>																						
<i>Single family detached dwelling unit</i>																						
<i>Servant's house</i>																						
<i>Temporary event</i>																						
<i>Two-house development (outside cluster unit development)</i>																						
<i>Transitional housing</i>																						
<i>Emergency shelter type A</i>																						
<i>Emergency shelter type B</i>																						
<i>Multi-unit supportive housing residence</i>																						
<i>Religious shelter/unit</i>																						
<i>Supportive housing residence</i>																						
<i>Unit-ownership (condominium) development (outside cluster unit development)</i>																						
<i>Utility apartment</i>																						
<i>Accessory residential family dwelling unit</i>																						
<i>Accessory residential unit</i>																						
<i>Manufactured home site</i>																						
<i>Mobile-home site</i>																						
<i>Mobile-home site with utility</i>																						
<i>Mobile-home site with utility and storage</i>																						
<i>Mobile-home site with utility and storage and parking</i>																						
<i>Mobile-home site with utility and storage and parking and storage</i>																						
<i>Mobile-home site with utility and storage and parking and storage and parking</i>																						
<i>Mobile-home site with utility and storage and parking and storage and parking and storage and parking and storage</i>																						

Special Use (City Council)  
 Special Use (Board of Adjustment)  
 SAs Plan Approval (City Council) required  
 Preliminary Site Plan Approval (Planning Comm. or City Council) may be required

General Use  
 Conditional Use

2-9-11

LAND USE	ZONING DISTRICTS																								
	RR	R-2	R-4	SP R-6	R-6	RM	R-10	R-15	R-20	SP R-30	CM	AP	FB	QA-1	QA-2	QA-3	BC	SB	SC	MB	SPS Zone	TD	L-1	L-2	
<b>INSTITUTION / CMIC / SERVICES</b>																									
Accessory fund raising activity for residential institutions																									
Accessory structure (kiosk, well, storage building)																									
Art gallery																									
Governmental																									
Non-governmental																									
Cemetery																									
Not for profit - church, family, government, including mausoleum and columbarium																									
Commercial																									
Charitable institution																									
Church, synagogue or religious education building																									
Civic club																									
Civic / convention center and assembly hall																									
Governmental																									
Non-governmental																									
Correctional / penal facility																									
Governmental																									
Non-governmental																									
Crematory																									
Day care facility (child or adult)																									
Greater than 50 enrollees																									
50 or less enrollees																									
Family child care home																									
Fire station, police precinct, training facility (not including outdoor firing range), and other emergency service facility																									
Funeral home																									
Governmental building and grounds not otherwise listed in this schedule																									

Special Use (City Council)  
 Special Use (Board of Adjustment)  
 Site Plan Approval (City Council) required  
 Preliminary Site Plan Approval (Planning Comm. or City Council) may be required

\*City Council site plan approval shall be required for buildings eight (80) feet in height or higher, which contain any occupiable room, as defined by the North Carolina State Building Code, or for uses located in the downtown area as set forth in §10-2132.2(5)(4).

2-9-11

12/04

PLANNING AND DEVELOPMENT

§ 10-2071

LAND USE	ZONING DISTRICTS																	
	RS	SP R-8	RM	RS-10	SP R-30	RS-30	AM	RS-10	RS-15	RS-20	SP R-30	RS-30	AM	RS-10	RS-15	RS-20	SP R-30	RS-30
<b>INSTITUTION/CIVIC / SERVICES (cont.)</b>																		
Hospital (medical / psychiatric)	[Pattern of symbols]																	
Library or museum	[Pattern of symbols]																	
Governmental	[Pattern of symbols]																	
Non-governmental	[Pattern of symbols]																	
Monastery, convent	[Pattern of symbols]																	
Orphanage	[Pattern of symbols]																	
Schools	[Pattern of symbols]																	
Public (elementary, middle and high)	[Pattern of symbols]																	
Private (parochial elementary, middle and high)	[Pattern of symbols]																	
Institution of higher education including college and university	[Pattern of symbols]																	
Technical and vocational institution	[Pattern of symbols]																	
Specialty school (as a limited income business in residential districts and Residential Business District)	[Pattern of symbols]																	
Special care facility	[Pattern of symbols]																	
50 or less employees	[Pattern of symbols]																	
Greater than 50 employees	[Pattern of symbols]																	
Temporary event	[Pattern of symbols]																	
Veterinary hospital	[Pattern of symbols]																	
Without a kennel/foalery	[Pattern of symbols]																	
With a kennel/foalery	[Pattern of symbols]																	
With the boarding of wild animals	[Pattern of symbols]																	

General Use  
 Conditional Use  
 Special Use (City Council)  
 Special Use (Board of Adjustment)  
 See Plan Approval (City Council) required  
 Preliminary Site Plan Approval (Planning Comm. or City Council) may be required

2-9-11

LAND USE	ZONING DISTRICTS
<b>OFFICE</b> Accessory structures (fences, walls, storage buildings) Office, agency, or studio of a professional or business agent, or political, labor or service association (including, but not limited to the following: Finance - banker, bonding agent, finance agent, insurance adjuster, insurance agent, investment agent and mortgage agent. Medical - associates of nurses, chiropractors, chiropodist, dentist, dental supply company, serving dentist and dental laboratories, orthodontist, optician, optician, physician, plasma center, clinic and veterinarian. Professional services - accountants, advertising agent, architect, artist, broker, <i>egg farmer</i> , comedian, (excluding barbering as defined in G.S. 86A-2), engineer, engineering research laboratory, government, hair replacement, landscape architect, lawyer, restaurant, business consulting agent, financial agent, realtor, securities agent, trust or real estate and trust agent. Other professional or service offices, studios or agency not otherwise listed as permitted in the zoning district <i>Office center</i> School, church or government building Studio, operating on a not-for-profit basis, for a professional, business, political, or labor or service association or agency. Temporary event, not to exceed 14 days <i>Use of Community Development</i>	<div style="display: flex; flex-direction: row-reverse;"> <div style="margin-right: 10px;"> <input type="checkbox"/> General Use  <input type="checkbox"/> Conditional Use                 </div> <div style="margin-right: 10px;"> <input checked="" type="checkbox"/> Special Use (City Council)  <input checked="" type="checkbox"/> Special Use (Board of Adjustment)                 </div> <div style="margin-right: 10px;"> <input checked="" type="checkbox"/> Site Plan Approval (City Council) required  <input checked="" type="checkbox"/> Preliminary Site Plan Approval (Planning Commission) required  <input checked="" type="checkbox"/> General manager required                 </div> </div>
	RR
	RR-1
	RR-2
	RR-3
	RR-4
	RR-5
	RR-6
	RR-7
	RR-8
	RR-9
	RR-10
	RR-11
	RR-12
	RR-13
	RR-14
	RR-15
	RR-16
	RR-17
	RR-18
	RR-19
	RR-20
	RR-21
	RR-22
	RR-23
	RR-24
	RR-25
	RR-26
	RR-27
	RR-28
	RR-29
	RR-30
	RR-31
	RR-32
	RR-33
	RR-34
	RR-35
	RR-36
	RR-37
	RR-38
	RR-39
	RR-40
	RR-41
	RR-42
	RR-43
	RR-44
	RR-45
	RR-46
	RR-47
	RR-48
	RR-49
	RR-50
	RR-51
	RR-52
	RR-53
	RR-54
	RR-55
	RR-56
	RR-57
	RR-58
	RR-59
	RR-60
	RR-61
	RR-62
	RR-63
	RR-64
	RR-65
	RR-66
	RR-67
	RR-68
	RR-69
	RR-70
	RR-71
	RR-72
	RR-73
	RR-74
	RR-75
	RR-76
	RR-77
	RR-78
	RR-79
	RR-80
	RR-81
	RR-82
	RR-83
	RR-84
	RR-85
	RR-86
	RR-87
	RR-88
	RR-89
	RR-90
	RR-91
	RR-92
	RR-93
	RR-94
	RR-95
	RR-96
	RR-97
	RR-98
	RR-99
	RR-100

\*City Council site plan approval shall be required for buildings eight (8) feet or higher, which contain any occupiable room, as defined by the North Carolina State Building Code, or for uses located in the downtown area as set forth in §10-222(c)(4).

2-9-11

7/08

PLANNING AND DEVELOPMENT

§ 10-2071

LAND USE	ZONING DISTRICTS																				
	RR	R-2	R-4	SR-R-6	R-6	MH	R-10	R-15	R-20	SR-R-30	GM	AP	RB	OR-L	OR-L-2	OR-L-3	SR	SR	SR	SR	
<b>COMMERCIAL*</b>																					
Accessory structure (fence, well storage building)																					
Adult establishment																					
Bank																					
Bar																					
Bar, nightclub, tavern, lounge																					
Beauty, nail and manicure, cosmetic art and barber shop																					
Bed and breakfast inn																					
Carwash facility																					
Located within two hundred (200) feet from the property line of either any lot which is developed with a dwelling, congregational, care or convalescent home, structure or vacant lot located in a residential zoning district																					
All other																					
Christmas tree, greens and ornamental outdoor display area sales between Nov. 15 and Dec. 31																					
(Bank: Ord. No. 1988-016-TC-181, § 25, TC-25-88, § 2-5; Bar: Ord. No. 1988-016-TC-181, § 25, TC-25-88, § 2-5; Beauty, nail and manicure, cosmetic art and barber shop: Ord. No. 1988-016-TC-181, § 25, TC-25-88, § 2-5; Bed and breakfast inn: Ord. No. 2003-019-TC-308, § 2, TC-2-07, § 4-4-03; Christmas tree: Ord. No. 1988-016-TC-181, § 1, TC-1-88, 4-7-88)																					

\*City Council site plan approval shall be required for buildings exceeding 80' feet in height or higher, which contain any occupiable room, as defined by the North Carolina State Building Code, or for uses located in the downtown area as set forth in § 10-2071.2(a)(4).

2-9-11

§ 10-2071

RALPHIGH CITY CODE

7/08

LAND USE	ZONING DISTRICTS																						
	BR	B-2	B-4	SR-B-5	B-5	MH	B-10	B-15	B-20	SP-B-30	CM	AP	BF	OK-1	OK-2	OK-3	BC	SC	MB	TD	L-2		
<b>COMMERCIAL (continued)</b>																							
Communications																							
<b>Direct service</b>																							
Radio and television studio																							
Telecommunication tower located on a building constructed for purposes other than direct telecommunication, independent antenna tower 30 ft or 30% of the height of the building, whichever is greater																							
Telecommunication tower less than 250 ft. in height																							
Telecommunication tower less than 250 ft. in height located on a residential institution premises																							
Telecommunication tower of 250 ft. in height, or does not meet the conditional use standards of a tower less than 250 ft. in height																							
Telegraph office																							
Dance, recording, music studio																							
<b>Printing establishment</b>																							
With no drive-thru, drive-in service and with no alcohol sales for on-premise consumption																							
With no drive-thru, drive-in service and with alcohol sales for on-premise consumption																							
With drive-thru, drive-in service, and with or without alcohol sales for on-premise consumption																							
Exterminating service																							
<b>Food store - retail</b>																							
(Communications Ord. No. 1894-672-TC-72, §1, TC-3-54, 4-19-04; Ord. No. 1985-692-TC-113, §2, TC-15-36, 8-1-85; Ord. No. 2000-725-TC-188, §1, TC-17-89, 2-15-00; Ord. No. 2003-872-TC-251, §8, TC-25-02, 2-4-03; Emergency Ord. No. 1898-616-TC-161, §25, TC-3-99, 8-3-99; Ord. No. 2003-570-TC-231, §10, TC-23-02, 4-4-03; Food Service Ord. No. 1898-616-TC-161, §25, TC-3-99, 8-3-99)																							

General Use  
 Conditional Use  
 Special Use (City Council)  
 Special Use (Board of Adjustment)  
 Size: 2500 sq. ft. or less  
 Preliminary Size: 2500 sq. ft. or less  
 City Council Approval (City Council) required  
 Preliminary City Council Approval (Planning Comm. or City Council) may be required



2-9-11

6/09

PLANNING AND DEVELOPMENT

8-10-2071

LAND USE	ZONING DISTRICTS																			
	SR	R-2	R-4	R-6	R-8	R-10	R-15	R-20	SD R-30	R-30	CM	AP	R-15	R-10	R-8	R-6	R-4	R-2	SR	
<b>COMMERCIAL (continued)</b>																				
<i>Hotel/Motel</i>																				
Without any lodging or dwelling units																				
Containing one (1) or more lodging units without either a microwave oven or one (1) or more cubic feet capacity, a burner cook top, or refrigerator with more than seven (7) cubic feet																				
Containing one (1) or more lodging units with a burner-cook top and/or refrigerator with more than seven (7) cubic feet																				
Containing one (1) or more dwelling units with cooking facilities and refrigerators of unlimited size																				
Interim use, redevelopment areas																				
Kennels / cattery																				
Mixed use <i>Master Plan Development</i>																				
Movie theater - indoor																				
Movie theater - outdoor																				
Parking facility - <i>practical use</i>																				
<i>Residential Institutions (off-site)</i>																				
Parking deck/garage																				
Parking lot																				
Motorpool																				
Plant nursery, fruit and vegetable stand																				
Post office																				
(Hotel/Motel: Ord. No. 1898-511-TC-158, SS, TC-27-95, 7-2-95; Ord. No. 1897-248-TC-160, S, TC-19-97, 12-2-97; <i>Mixed Use</i> - Ord. No. 1899-676-TC-181, SS, TC-3-99, 8-3-99; Parking facility, <i>practical use</i> : Ord. No. 1899-516-TC-181, SS, 27, TC-3-99, 8-3-99)																				

Size Plan Approval (City Council) required  
Preliminary Size Plan Approval (Planning Comm. or City Council) may be required

Special Use (City Council)  
Special Use (Board of Adjustment)

General Use  
Conditional Use

10/2/D-11

2-9-11

§ 10-2071

RALEIGH CITY CODE

6/09

LAND USE	ZONING DISTRICTS																									
	RR	R-2	R-4	SP R-6	R-6	MIN	RC-10	R-15	R-20	SP R-30	R-30	GM	MP	RP	O&I-1	O&I-2	O&I-3	RD	SD	MB	BUS Zone	TD	M-1	R-2		
<b>COMMERCIAL (continued)</b>																										
Retail sales																										
Residential related service (e.g. beauty shop, drug store, eating establishment, gift shop, laundry, newsstand)																										
Nonresidential related service (general) (e.g. writing establishment, flower shop, gift shop, laundry and dry cleaning (pick-up), newsstand, office supply sales)																										
Personal service (laundry and dry cleaning (with pickup or walk-up services); photography studio, shoe repair shop...)																										
Convenience (repairs, scissors, optics, film developing, food, furniture, gifts, hardware, jewelry, launches with or without drive-thru, music, shoes, sporting goods, toys...)																										
Pawn shop																										
Outdoor Mobile Vending Cart (see Retail sales-outdoor mobile vending cart)																										
General (e.g. department store, discount store, home building supply store) :																										
(Paw sales: Ord. No. 1994-408-TC-75, §4, TC-9-94, 6-7-94; Ord. No. 1995-516-TC-181, §3/4, 25, TC-3-95, 8-3-95; Convenience: Ord. No. 1999-616-TC-181, §24, TC-3-99, 3-3-99; General: Ord. No. 1999-676-TC-181, §24, TC-3-99, 8-3-99; Outdoor: Ord. No. 2005-655-TC-884, §2, TC-17-05, 4-4-06; Pawn shop: Ord. No. 2005-586-TC-320, §2, TC-17-08, 2-17-09)																										

General Use  
 Special Use (City Council)  
 Special Use (Board of Adjustment)  
 Site Plan Approval (City Council) required  
 Preliminary Site Plan Approval (Planning Comm. or City Council) may be required.

2-9-11

12/99

PLANNING AND DEVELOPMENT

§10-2071

LAND USE	ZONING DISTRICTS																									
	RR	R-2	R-4	SP R-8	R-6	MH	R-10	R-15	R-20	SP R-30	R-90	CM	AP	RB	OA-1	OA-2	OA-3	BC	SC	NB	Bus Zone	TD	L-1	L-2		
COMMERCIAL (continued)																										
<i>Equipment</i> (e.g. equipment sales/repair, vehicle sales/repair, automotive service and repair facility)																										
<i>Retail</i> sales not otherwise listed as a permitted general or conditional use																										
(Highway: Ord. No. 1999-616-TC-181, §24, TC-3-99, 8-3-99; Retail sales: Ord. No. 1999-616-TC-181, §24, TC-3-99, 8-3-99)																										

Special Use (City Council)  
 Special Use (Board of Adjustment)  
 Site Plan Approval (City Council) required  
 Preliminary Site Plan Approval (Planning Comm. or City Council) may be required

General Use  
 Conditional Use

2-9-11

§10-2071

RALBIGH CITY CODE

12/99

LAND USE	ZONING DISTRICTS																							
	RR	R-2	R-4	SP R-6	R-6	MH	R-10	R-15	R-20	SP R-30	R-30	CM	AP	RB	QA-1	QA-2	QA-3	BC	SC	NB	TD	L1	L2	
COMMERCIAL (continued)																								
Shopping area																								
Shopping center																								
Temporary event																								
Trade show and temporary retail activity within a hotel/motel																								

General Use  
 Conditional Use  
 Special Use (City Council)  
 Special Use (Board of Adjustment)  
 Size/Fees Approval (City Council) required  
 Preliminary Size/Fees Approval (Planning Comm. of City Council) may be required

2-9-11



LAND USE	ZONING DISTRICTS																
	RR-2	RR-4	RR-5	RR-6	RR-10	RR-15	RR-20	RR-30	RR-35	RR-40	RR-45	RR-50	RR-55	RR-60	RR-65	RR-70	
<b>INDUSTRIAL*</b>																	
Auxiliary structure (barn, well, storage building)	○	○	○	○	○	○	○	○	○	○	○	○	○	○	○	○	○
Billboard (off-premise sign)																	
Bottling plant																	
Box products (sorting, breaking)																	
Bulk storage of flammable and combustible liquids if a governmental water supply is available for fire-fighting purposes																	
Excavator																	
Machine shop																	
Machinery																	
Custom (barn / shop for custom work)																	
Specialized (assembly of scientific measuring, clocks, medical, musical instruments, watches...)																	
Restricted (within the First Fire District - see map in § 10-2078(e))																	
General																	
Tanning and quarrying																	
Milk washhouse/storage facility																	
Kiln or compost processing facility																	
Outdoor storage																	
Building materials or contractors construction equipment																	
Coal yard, lumber yard and lumber mill																	
Recyclable materials																	
Unlicensed, uninspected, wrecked, crushed, dismantled or partially dismantled vehicles (more than one (1))																	
Reservoir and water control structures																	
Storage materials - INDOOR STORAGE																	

General Use  
 Conditional Use  
 Special Use (City Council)  
 Special Use (Board of Adjustment)  
 Site Plan Approval (City Council) required  
 Preliminary Site Plan Approval (Planning Comm. or City Council) may be required

\*City Council site plan approval shall be required for buildings eight (8) feet in height or higher, which contain any occupiable room, as defined by the North Carolina State Building Code, or for uses located in the downtown area as set forth in § 10-2132.20(k).

2-9-11

LAND USE	ZONING DISTRICTS																								
	RR	R-2	R-4	SP R-6	R-8	MH	R-10	R-15	R-20	SP R-30	R-30	CM	AP	RB	O&I-1	O&I-2	O&I-3	BC	SC	NB	TD	BISS Zone	I-1	I-2	
<b>INDUSTRIAL (continued)</b>																									
Solid waste																									
Indoor recreation																									
Outdoor recreation																									
Landfill (Excludes from on-site Landfill (all other lawfully approved)																									
Temporary event																									
Transportation																									
Airfield or landing strip																									
Airport																									
Heliports serving hospitals licensed by the State of North Carolina pursuant to N.C. Gen. Stat. §(31E-176) et. sec. and that operate acute care beds as defined by 10A N.C.A.C. 14C.3801																									
Heliports serving all other uses																									
Railroad freight station or stop																									
Railroad transit station or stop																									
Passenger transit stop																									
Taxicab dispatch stand																									
Taxicab stand																									
Terminal facility, railroad roundhouse and depot																									

General Use  
 Conditional Use  
 Special Use (City Council)  
 Special Use (Board of Adjustment)  
 Site Plan Approval (City Council) required  
 Preliminary Site Plan Approval (Planning Comm. or City Council) may be required

2-9-11

LAND USE	ZONING DISTRICTS																						
	RR	R-2	R-4	SP R-6	MH	R-10	R-15	R-20	SP R-30	CM	AP	RB	OA-1	OA-2	OA-3	BC	SC	NB	TD	Bus Zone	L1	L2	
<b>INDUSTRIAL (continued)</b>																							
Utilities																							
Conversion of a utility to another utility use or a municipal use																							
Gas plant																							
Power plant																							
Electrical generating plant powered by wind, water or solar																							
Other power plants																							
Substation																							
Utility services																							
Water or sanitary sewer treatment plant																							
Governmental																							
Community																							
Warehousing / distribution center																							
Wholesale laundry, dyeing and dry cleaning																							
Wholesaling																							
<b>NONGOVERNMENTAL USE OR TRADE NOT OTHERWISE PROHIBITED</b>																							
(Outdoor storage, identified vehicles: Ord. No. 1888-194-TC-47, §3, TC-143, 20-208, 20-209, 20-210, 20-211, 20-212, 20-213, 20-214, 20-215, 20-216, 20-217, 20-218, 20-219, 20-220, 20-221, 20-222, 20-223, 20-224, 20-225, 20-226, 20-227, 20-228, 20-229, 20-230, 20-231, 20-232, 20-233, 20-234, 20-235, 20-236, 20-237, 20-238, 20-239, 20-240, 20-241, 20-242, 20-243, 20-244, 20-245, 20-246, 20-247, 20-248, 20-249, 20-250, 20-251, 20-252, 20-253, 20-254, 20-255, 20-256, 20-257, 20-258, 20-259, 20-260, 20-261, 20-262, 20-263, 20-264, 20-265, 20-266, 20-267, 20-268, 20-269, 20-270, 20-271, 20-272, 20-273, 20-274, 20-275, 20-276, 20-277, 20-278, 20-279, 20-280, 20-281, 20-282, 20-283, 20-284, 20-285, 20-286, 20-287, 20-288, 20-289, 20-290, 20-291, 20-292, 20-293, 20-294, 20-295, 20-296, 20-297, 20-298, 20-299, 20-300, 20-301, 20-302, 20-303, 20-304, 20-305, 20-306, 20-307, 20-308, 20-309, 20-310, 20-311, 20-312, 20-313, 20-314, 20-315, 20-316, 20-317, 20-318, 20-319, 20-320, 20-321, 20-322, 20-323, 20-324, 20-325, 20-326, 20-327, 20-328, 20-329, 20-330, 20-331, 20-332, 20-333, 20-334, 20-335, 20-336, 20-337, 20-338, 20-339, 20-340, 20-341, 20-342, 20-343, 20-344, 20-345, 20-346, 20-347, 20-348, 20-349, 20-350, 20-351, 20-352, 20-353, 20-354, 20-355, 20-356, 20-357, 20-358, 20-359, 20-360, 20-361, 20-362, 20-363, 20-364, 20-365, 20-366, 20-367, 20-368, 20-369, 20-370, 20-371, 20-372, 20-373, 20-374, 20-375, 20-376, 20-377, 20-378, 20-379, 20-380, 20-381, 20-382, 20-383, 20-384, 20-385, 20-386, 20-387, 20-388, 20-389, 20-390, 20-391, 20-392, 20-393, 20-394, 20-395, 20-396, 20-397, 20-398, 20-399, 20-400, 20-401, 20-402, 20-403, 20-404, 20-405, 20-406, 20-407, 20-408, 20-409, 20-410, 20-411, 20-412, 20-413, 20-414, 20-415, 20-416, 20-417, 20-418, 20-419, 20-420, 20-421, 20-422, 20-423, 20-424, 20-425, 20-426, 20-427, 20-428, 20-429, 20-430, 20-431, 20-432, 20-433, 20-434, 20-435, 20-436, 20-437, 20-438, 20-439, 20-440, 20-441, 20-442, 20-443, 20-444, 20-445, 20-446, 20-447, 20-448, 20-449, 20-450, 20-451, 20-452, 20-453, 20-454, 20-455, 20-456, 20-457, 20-458, 20-459, 20-460, 20-461, 20-462, 20-463, 20-464, 20-465, 20-466, 20-467, 20-468, 20-469, 20-470, 20-471, 20-472, 20-473, 20-474, 20-475, 20-476, 20-477, 20-478, 20-479, 20-480, 20-481, 20-482, 20-483, 20-484, 20-485, 20-486, 20-487, 20-488, 20-489, 20-490, 20-491, 20-492, 20-493, 20-494, 20-495, 20-496, 20-497, 20-498, 20-499, 20-500, 20-501, 20-502, 20-503, 20-504, 20-505, 20-506, 20-507, 20-508, 20-509, 20-510, 20-511, 20-512, 20-513, 20-514, 20-515, 20-516, 20-517, 20-518, 20-519, 20-520, 20-521, 20-522, 20-523, 20-524, 20-525, 20-526, 20-527, 20-528, 20-529, 20-530, 20-531, 20-532, 20-533, 20-534, 20-535, 20-536, 20-537, 20-538, 20-539, 20-540, 20-541, 20-542, 20-543, 20-544, 20-545, 20-546, 20-547, 20-548, 20-549, 20-550, 20-551, 20-552, 20-553, 20-554, 20-555, 20-556, 20-557, 20-558, 20-559, 20-560, 20-561, 20-562, 20-563, 20-564, 20-565, 20-566, 20-567, 20-568, 20-569, 20-570, 20-571, 20-572, 20-573, 20-574, 20-575, 20-576, 20-577, 20-578, 20-579, 20-580, 20-581, 20-582, 20-583, 20-584, 20-585, 20-586, 20-587, 20-588, 20-589, 20-590, 20-591, 20-592, 20-593, 20-594, 20-595, 20-596, 20-597, 20-598, 20-599, 20-600, 20-601, 20-602, 20-603, 20-604, 20-605, 20-606, 20-607, 20-608, 20-609, 20-610, 20-611, 20-612, 20-613, 20-614, 20-615, 20-616, 20-617, 20-618, 20-619, 20-620, 20-621, 20-622, 20-623, 20-624, 20-625, 20-626, 20-627, 20-628, 20-629, 20-630, 20-631, 20-632, 20-633, 20-634, 20-635, 20-636, 20-637, 20-638, 20-639, 20-640, 20-641, 20-642, 20-643, 20-644, 20-645, 20-646, 20-647, 20-648, 20-649, 20-650, 20-651, 20-652, 20-653, 20-654, 20-655, 20-656, 20-657, 20-658, 20-659, 20-660, 20-661, 20-662, 20-663, 20-664, 20-665, 20-666, 20-667, 20-668, 20-669, 20-670, 20-671, 20-672, 20-673, 20-674, 20-675, 20-676, 20-677, 20-678, 20-679, 20-680, 20-681, 20-682, 20-683, 20-684, 20-685, 20-686, 20-687, 20-688, 20-689, 20-690, 20-691, 20-692, 20-693, 20-694, 20-695, 20-696, 20-697, 20-698, 20-699, 20-700, 20-701, 20-702, 20-703, 20-704, 20-705, 20-706, 20-707, 20-708, 20-709, 20-710, 20-711, 20-712, 20-713, 20-714, 20-715, 20-716, 20-717, 20-718, 20-719, 20-720, 20-721, 20-722, 20-723, 20-724, 20-725, 20-726, 20-727, 20-728, 20-729, 20-730, 20-731, 20-732, 20-733, 20-734, 20-735, 20-736, 20-737, 20-738, 20-739, 20-740, 20-741, 20-742, 20-743, 20-744, 20-745, 20-746, 20-747, 20-748, 20-749, 20-750, 20-751, 20-752, 20-753, 20-754, 20-755, 20-756, 20-757, 20-758, 20-759, 20-760, 20-761, 20-762, 20-763, 20-764, 20-765, 20-766, 20-767, 20-768, 20-769, 20-770, 20-771, 20-772, 20-773, 20-774, 20-775, 20-776, 20-777, 20-778, 20-779, 20-780, 20-781, 20-782, 20-783, 20-784, 20-785, 20-786, 20-787, 20-788, 20-789, 20-790, 20-791, 20-792, 20-793, 20-794, 20-795, 20-796, 20-797, 20-798, 20-799, 20-800, 20-801, 20-802, 20-803, 20-804, 20-805, 20-806, 20-807, 20-808, 20-809, 20-810, 20-811, 20-812, 20-813, 20-814, 20-815, 20-816, 20-817, 20-818, 20-819, 20-820, 20-821, 20-822, 20-823, 20-824, 20-825, 20-826, 20-827, 20-828, 20-829, 20-830, 20-831, 20-832, 20-833, 20-834, 20-835, 20-836, 20-837, 20-838, 20-839, 20-840, 20-841, 20-842, 20-843, 20-844, 20-845, 20-846, 20-847, 20-848, 20-849, 20-850, 20-851, 20-852, 20-853, 20-854, 20-855, 20-856, 20-857, 20-858, 20-859, 20-860, 20-861, 20-862, 20-863, 20-864, 20-865, 20-866, 20-867, 20-868, 20-869, 20-870, 20-871, 20-872, 20-873, 20-874, 20-875, 20-876, 20-877, 20-878, 20-879, 20-880, 20-881, 20-882, 20-883, 20-884, 20-885, 20-886, 20-887, 20-888, 20-889, 20-890, 20-891, 20-892, 20-893, 20-894, 20-895, 20-896, 20-897, 20-898, 20-899, 20-900, 20-901, 20-902, 20-903, 20-904, 20-905, 20-906, 20-907, 20-908, 20-909, 20-910, 20-911, 20-912, 20-913, 20-914, 20-915, 20-916, 20-917, 20-918, 20-919, 20-920, 20-921, 20-922, 20-923, 20-924, 20-925, 20-926, 20-927, 20-928, 20-929, 20-930, 20-931, 20-932, 20-933, 20-934, 20-935, 20-936, 20-937, 20-938, 20-939, 20-940, 20-941, 20-942, 20-943, 20-944, 20-945, 20-946, 20-947, 20-948, 20-949, 20-950, 20-951, 20-952, 20-953, 20-954, 20-955, 20-956, 20-957, 20-958, 20-959, 20-960, 20-961, 20-962, 20-963, 20-964, 20-965, 20-966, 20-967, 20-968, 20-969, 20-970, 20-971, 20-972, 20-973, 20-974, 20-975, 20-976, 20-977, 20-978, 20-979, 20-980, 20-981, 20-982, 20-983, 20-984, 20-985, 20-986, 20-987, 20-988, 20-989, 20-990, 20-991, 20-992, 20-993, 20-994, 20-995, 20-996, 20-997, 20-998, 20-999, 20-1000)																							

Editor's notes: Section 45 of Ord. No. 1997-137-TC-153, TC-18-96, adopted June 17, 1997, made major changes to this Schedule of Permitted Land Uses in Zoning Districts. For specific information on these changes, too numerous to history note individually within the schedule, please see Ord. No. 1997-137-TC-153.

General Use  
 Conditional Use  
 Special Use (City Council)  
 Special Use (Board of Adjustment)  
 Site Plan Approval (City Council) required  
 Preliminary Site Plan Approval (Planning Comm. or City Council) may be required

(Ord. No. 1996-370-TC-167, §12, TC-3-98, 7-7-98)

---

# CRABTREE PLACE

---

## Streetscape and Parking Plan

Raleigh, North Carolina  
Case Number Z-09-11

Date: June 3, 2011  
Revised: June 13, 2011  
August 2, 2011

Owner:  
WEINGARTEN/INVESTMENTS, INC.  
9420 Forum Drive, Suite 101  
Raleigh, NC 27615

Prepared By:



THE JOHN R. McADAMS  
COMPANY, INC.

ENGINEERS • PLANNERS • SURVEYORS • ENVIRONMENTAL

RESEARCH TRIANGLE PARK • CHARLOTTE • WILMINGTON

800-733-5646 • [www.johnr-mcadams.com](http://www.johnr-mcadams.com)



**Table of Contents**

---

**Introduction**

Location Map	Page 3
Site History	Page 3
Planning Objective	Page 3
Zoning/PBOD Boundary Exhibit	Page 4
Transportation	Page 5
Streetscape Concept	Page 5
Alternate Streetscape Concept	Page 6
Streetscape Standards	Page 7

**Streetscape Standards**

Sidewalk Plans and Sections	Pages 8-11
Curb and Sidewalk Details	Page 12
Accent Paver Detail	Page 12
Utilities	Page 13
Maintenance Plan	Page 13
Signage	Page 13
Canopies and Awnings	Page 13
Street Lights	Page 13
Pedestrian Lighting	Page 14
Low Level Lighting	Page 14
Building Facades	Page 15
Building Setbacks	Page 15
Building heights	Page 15
Parking	Page 15
Parking Location Diagram	Page 15
Street Trees	Page 17-18
Tree Grates	Page 19
Street Tree Planting Details	Page 19
Bench, Trash Receptacles and Bike Racks Details	Page 20-21
Appendix – City Code Section 10-2055 (PBOD)	Page 22

**Introduction**

---

**Location Map**

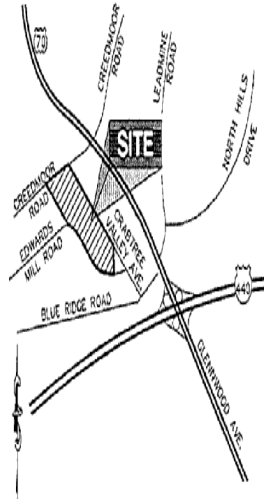

**Site History**

This 11.73 acre site, once containing a traditional shopping center and a couple of standalone restaurants, was demolished in 2004 in association with plans for re-development. This site's prominent location, adjacent to Crabtree Valley Mall and at the crossroads of two major thoroughfares, makes it a prime candidate for redevelopment into a vibrant center containing a mixture of uses and providing a place for people to live, shop and recreate. The property is currently subject to a Planned Development District that was instigated by a previous owner. As time has passed and the market has changed, the constraints of the current PDD have proven impractical to abide by and thus the current owner is seeking alternate zoning through the implementation of a Shopping Center CUD with a PBOD to facilitate a mixture of complimentary uses on the site.

**Planning Objective**

Crabtree Place will incorporate a high density, urban infill residential development located immediately adjacent to Crabtree Valley Mall which is one of the largest retail malls in North Carolina. The incorporation of the PBOD at this location will complete a key link to Crabtree Valley Mall which will help draw pedestrian traffic from the residential at Crabtree Place as well as the existing neighboring communities to the south.

Through the use of site features such as expanded walkways, decorative crosswalks, pedestrian scale lighting and enhanced street furnishings, the project will provide an inviting corridor for pedestrian travel both to and through the project.

The goal of this streetscape and parking plan is to provide a framework for development of sections 1 and 2 of the project as shown on the rezoning exhibit below. The site is currently a missing piece in the framework of this vibrant retail node. By providing these guidelines for development, we can insure that this void is ultimately filled with a pedestrian friendly urban project, unified by a common streetscape theme.

The streetscape and public spaces are intended to support the urban nature this site offers. In order to facilitate an inviting pedestrian scale streetscape, the plan will regulate items such as building setbacks, pedestrian walkways, paving patterns and finishes, landscaping and street furnishings.

By providing this framework, the project will have the opportunity to develop over time and yet still maintain a cohesive development pattern that holds together as a unified project that will stand the test of time.

**Zoning/PBOD Boundary Exhibit**

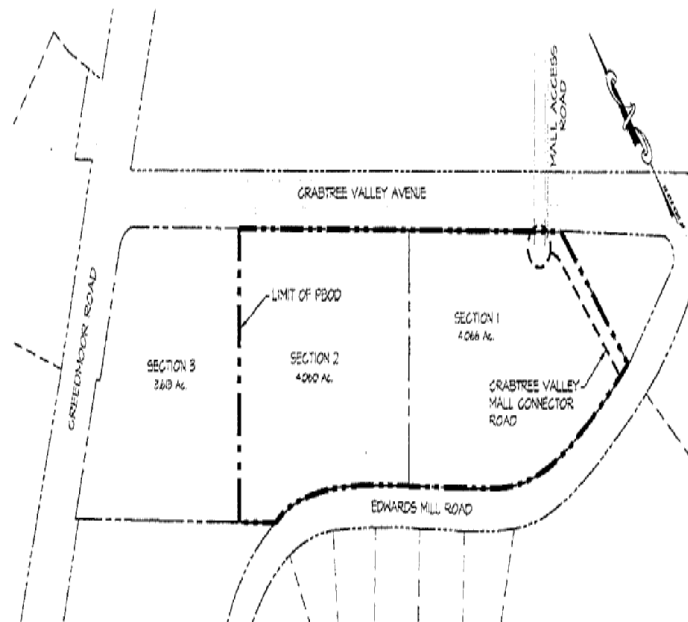

**Transportation**

The site is located in the southeast quadrant of Creedmoor Road and Crabtree Valley Avenue. In addition, the site is immediately adjacent to Crabtree Valley Mall at a major crossroads of activity for vehicular and bus traffic.

One of the potential challenges this site faces is the unique topography along both the north and south frontages of the site. Crabtree Valley Avenue is currently 20'-25' below the elevation of the site, while Edwards Mill Road to the south rises to 25' above the site. This configuration makes access to the site very difficult. In addition, the City of Raleigh has plans to re-align Crabtree Valley Avenue to intersect with Creedmoor Road on the south side of the property. Under this scenario, the current location of Crabtree Valley Avenue would be vacated. We support the concept of these plans and are working with the City to help define the best approach to accommodating the future conditions along our project's southern frontage. It is unclear at this point as to the timing of these improvements, but for the sake of designing our streetscape, we have assumed that Crabtree Valley Avenue will be relocated. In the event the road is not relocated, we will propose alternate streetscape concepts as discussed below on pages 6-7.

In addition to vehicular transportation, there are bus lines currently running along all frontages of the property, with a transfer station located within walking distance of the site inside the parking structure of Crabtree Valley Mall. Upon approval of a site plan or plans for the development of all or a portion of the 11.73 acres subject to this zoning case, if requested by the City's Transit Division, the owner shall dedicate a transit easement upon the respective site or sites of a size, nature and location acceptable to such Division and provide any improvements, such as a bench and/or shelter, specified by such Division that will be in accordance with its standard policies. The owner shall dedicate up to three (3) transit easements upon the 11.73 acres subject to this zoning case.

This framework of transportation modes offer excellent support for a high density residential project mixed with a number of other uses such as retail, office and/or hospitality.

**Streetscape Concept**

The overall streetscape concept has been designed to provide a pedestrian scale experience. It is very likely that both of our frontages will ultimately carry a great deal of vehicular traffic, especially after the relocation of Crabtree Valley Avenue. As such, it is important to incorporate streetscape elements that give the pedestrian a sense of safety as they pass through the property.

***Re-Aligned Crabtree Valley Avenue Frontage***

In order to protect the pedestrian from vehicular traffic, we plan to intersperse a series of curbside planting beds between the sidewalk and curb, allowing for a row of low plantings as well as seasonal color. In addition, street trees located in tree grates will be provided at a minimum

of 40' o.c. with decorative pedestrian scale lighting, benches, trash receptacles and bike racks placed regularly along the streetscape. The pedestrian walkways will also incorporate brick banding to further accentuate the edges of the walkway and tree grates. We have also incorporated a planting strip between the back of the sidewalk and the building in order to break up the façade of the building and soften the streetscape with additional plantings. Final location of the brick bands and street furnishing will be finalized at site plan approval.

***Crabtree Valley Mall Connector Road Frontage***

This connector road will ultimately act as a major access point to Crabtree Valley Mall. As such, we have designed this frontage to slow pass-through traffic by providing on-street parallel parking on both sides of the street. It is likely that this frontage will contain access points to the building so we would anticipate the facade location closer to the back of curb than along the Edwards Mill Frontage. This streetscape contains a mixture of curbside and building-side planters as well as sections where the entire streetscape is paved to facilitate pedestrian circulation. This frontage will also incorporate street trees at a minimum of 40' o.c. with decorative pedestrian scale lighting, benches, trash receptacles and bike racks placed regularly along the streetscape. The actual location of the "Crabtree Valley Mall Connector Road" shown on pages 4 and 16 will be established at the time of site plan approval.

**Alternative Streetscape Concept (if Crabtree Valley Avenue is not Re-Aligned)**

***Existing Edwards Mill Road***

In the event the re-alignment of Crabtree Valley Avenue is not approved, or, if approved, is unfunded and delayed and existing Edwards Mill Road stays in place, in view of the drastic grade separation between Edwards Mill Road and the finished grade of the project, an alternate streetscape concept will be implemented that locates the 14' wide pedestrian walk adjacent to the building(s) and at the same finished elevation.

***Existing Crabtree Valley Avenue***

If Crabtree Valley Avenue is re-aligned as proposed, or if such re-alignment is approved and funded, there will be no improvements to the streetscape along the existing right of way of Crabtree Valley Avenue. If such re-alignment is approved and is unfunded, and development of the PBOD site commences, streetscape improvements along the right-of-way of existing Crabtree Valley Avenue will be delayed for a period of two years following issuance of a final certificate of occupancy for the project. Upon the expiration of that period, if the re-alignment has been funded, there will be no improvements to the streetscape along such right of way. If funding for the approved re-alignment has not been provided at that time, and if the Planning Director so directs, a walkway 14' in width (consistent with that proposed for re-aligned Crabtree

Valley Avenue) will be constructed along such frontage of the site adjacent to, and at the same grade as, building(s) on the site. If the re-alignment of Crabtree Valley Avenue is not approved, upon development of the PBOD site, the 14' wide walkway adjacent to, and at the grade of, the building(s) will be constructed. If under any circumstance the developer is required to provide a sidewalk at the grade of existing Crabtree Valley Avenue and at the grade of the project, the cumulative width of sidewalks along such frontage of existing Crabtree Valley Avenue will not exceed 14'.

### **Streetscape Standards**

---

#### **Width of Pedestrian Ways**

There are currently no existing sidewalks adjacent to the boundary of the proposed PBOD. As required, we will provide new sidewalks in accordance with the foregoing text and, as applicable, the sections and plans illustrated below.

**Re-Aligned Crabtree Valley Avenue Frontage** – This frontage will be improved with a full 14' wide streetscape in accordance with City of Raleigh PBOD standards (see illustration below).

**Crabtree Valley Mall Connector Road (east frontage)** – The connector road between Edwards Mill Road and Crabtree Valley Mall will be improved with a full 14' wide streetscape in accordance with City of Raleigh PBOD standards (see illustration below).

#### **Pedestrian Crosswalk locations**

Pedestrian crosswalks will be provided at the intersection of Edwards Mill and Crabtree valley Mall Connector Roads as well as at any point where a street or driveway crosses the pedestrian travel way. Crosswalks will be designed in accordance with accessibility requirements.

Re-Aligned Crabtree Valley Avenue Plan

Note: Final location of site furnishings, planters and brick bands to be determined at site plan approval.  
 Plan illustrates the minimum level of brick banding proposed.

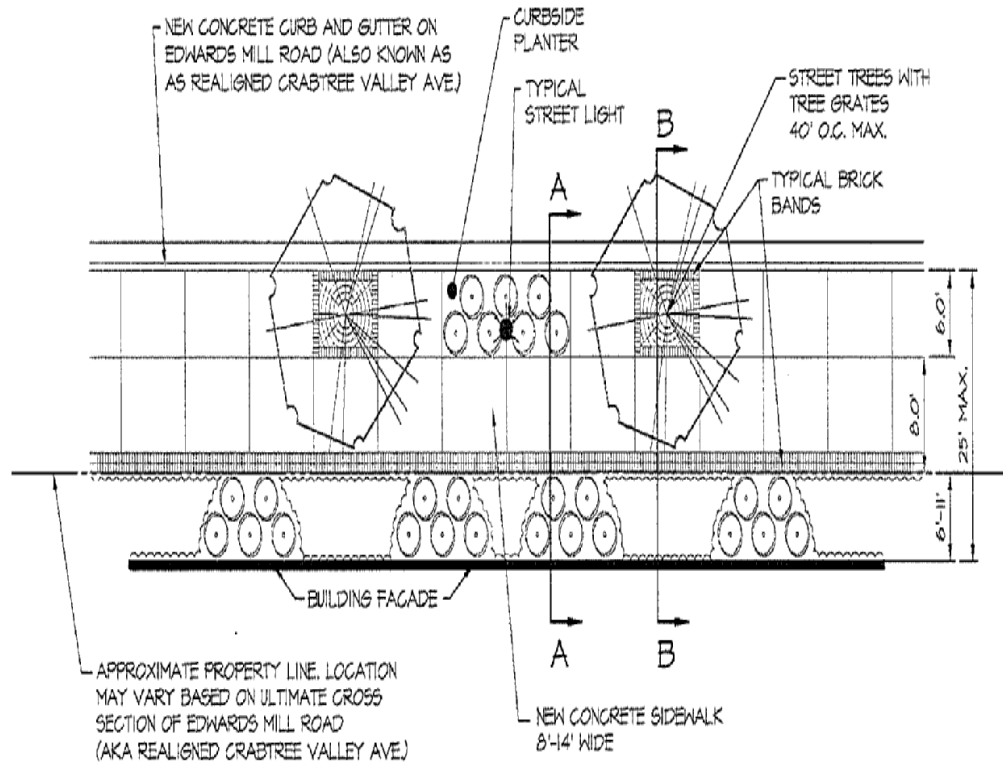

Re-Aligned Crabtree Valley Avenue Sidewalk Sections

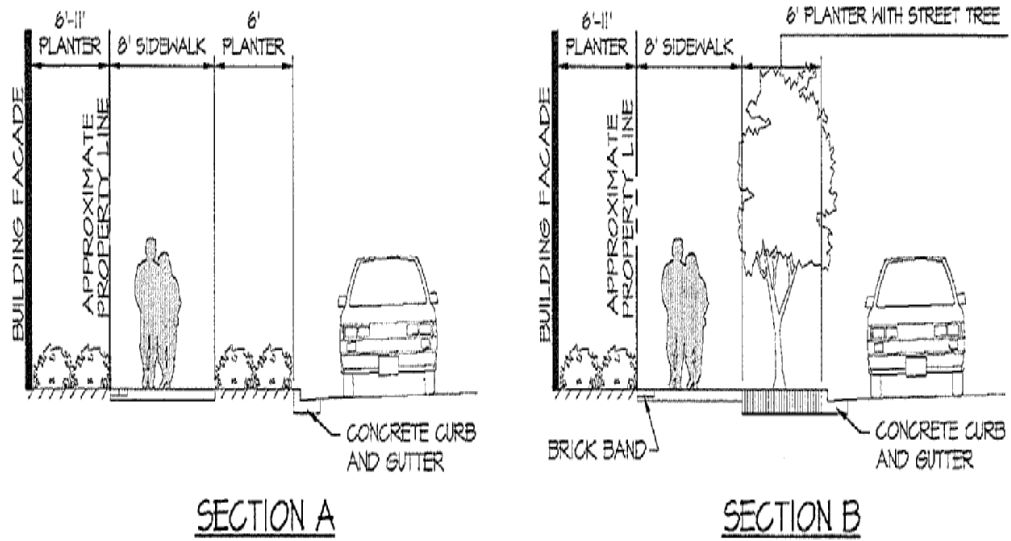



Crabtree Valley Mall Connector Road Sidewalk Plan

Note: Final location of planters and site furnishings to be determined at site plan approval.

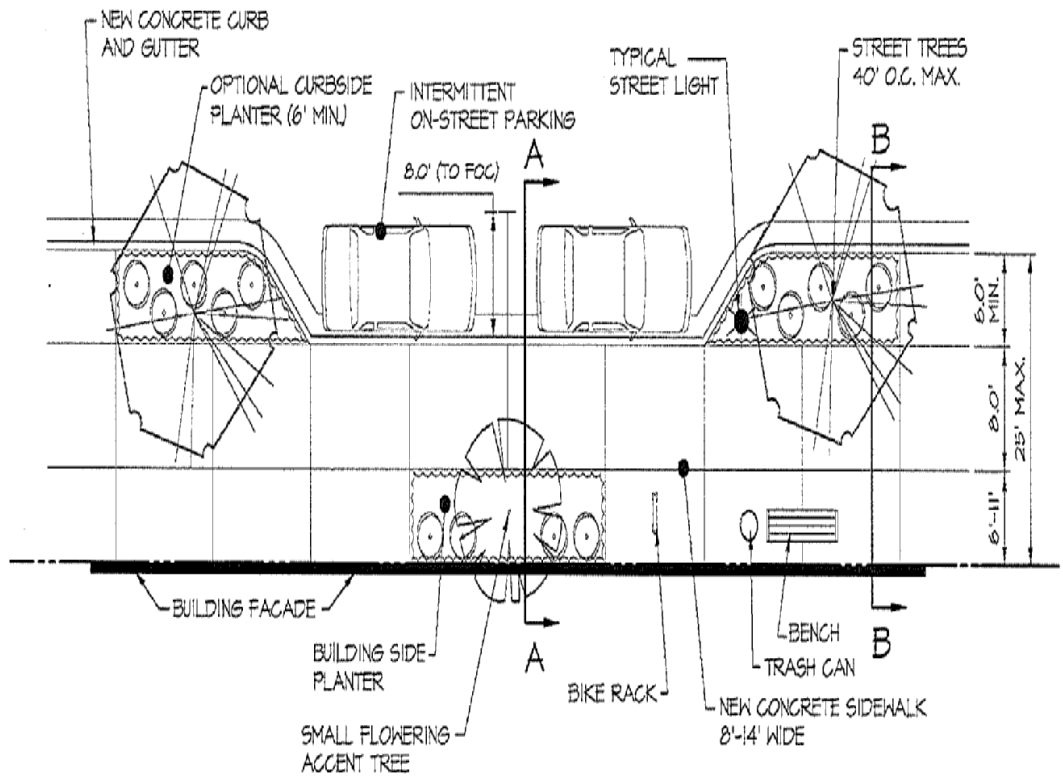

Crabtree Valley Mall Connector Road Sidewalk Sections

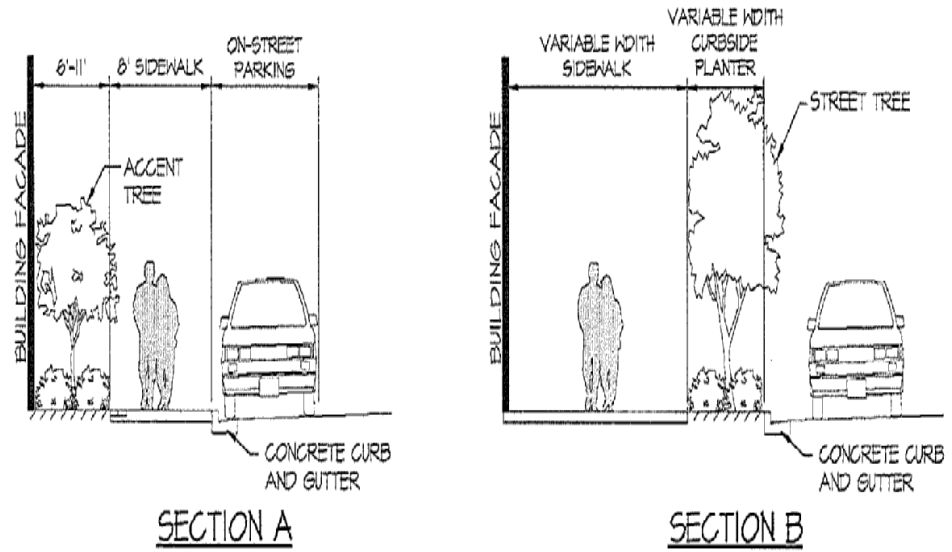

**Curb Detail**

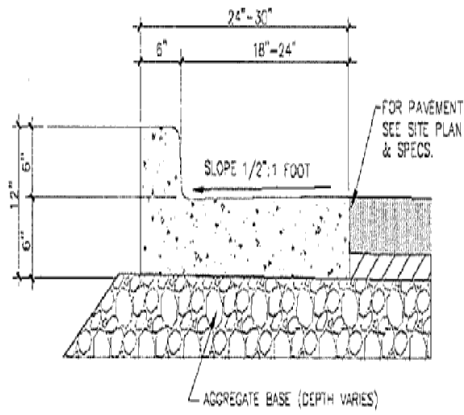

**Sidewalk Details**

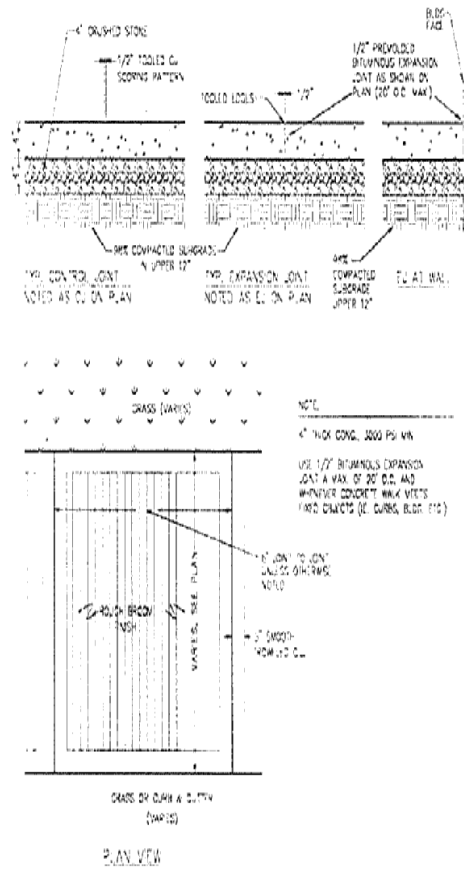

**Accent Paver Detail**

Manufacturer: Pine Hall Brick  
Specification: Cocoa Full Range (or equal as approved by staff at the time of site plan approval).

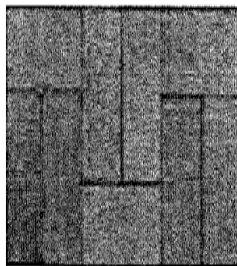

**Streetscape Standards Continued**

---

**Utilities**

Utilities are currently in place in the area. Subject to approval by the City of Raleigh and the utility provider, all utilities will be either located underground and behind the back of curb or on poles in the right of way.

**Maintenance Plan**

A maintenance plan will be enforced as part of the PBOD for the care of the streetscape improvements up to the public right-of-way. Maintenance in excess of that customarily provided by the municipality within public right-of-ways will require an encroachment agreement and will be the responsibility of the individual property owners. This includes maintenance of sidewalks and planters and street furnishings required by the PBOD but within the property lines, watering of plant materials and keeping the sidewalks free of debris and trash. A draft of the maintenance plan will be submitted at the time of site plan approval.

**Signage**

The design and location of signage will compliment the architectural styles of the structures and will be oriented toward vehicular and pedestrian traffic. The following signage types are encouraged: Awning signs, window stencils and wall signs. Low profile ground signs will also be allowed on the property in accordance with the signage code. Paddle signs oriented toward pedestrian traffic will also be permitted in accordance with the signage code and shall maintain a clear minimum height of 9'-0" above the ground.

**Canopies and Awnings**

In the event canopies or awnings are incorporated along the streetscape; they will be of sufficient height to accommodate the free flow of pedestrian traffic. In no case will the awnings be less than 9'-0" above the ground.

**Street Lights**

Appropriate light levels along the streetscapes and parking areas are critical in creating a safe and inviting environment for pedestrians. The project will provide a mix of low level lighting as well as pedestrian scale lighting similar to the illustrations provided below. A lighting plan will be provided at the time of site plan approval.

**Pedestrian Lighting**

Manufacturer: Landscapeforms  
Specification: Alcott 12' Pedestrian light  
(or approved equal)

**Low Level Lighting**

Manufacturer: Landscapeform  
Specification: Alcott 12' Pedestrian light  
(or approved equal)

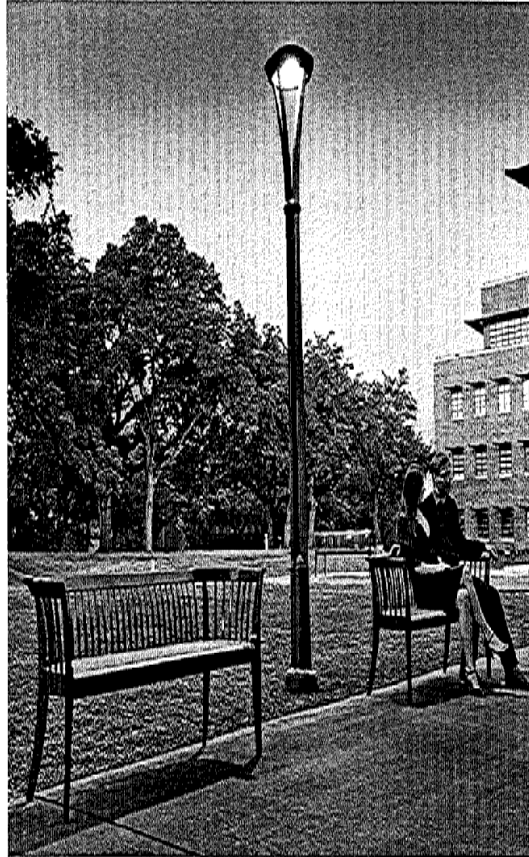

**Building Facades**

Structures will address the public and private rights of ways. Ground level residential units will have one or more of the following elements: balconies, porches, stoops or similar active elements that address the street in order to help mitigate the interface between the proposed residential structure and the existing residential to the south.

Along the streetscape, the facades will be broken up to provide a pedestrian scale experience by the interspersions of street trees, street furnishings, decorative lighting, movement in the sidewalk, changes in paving material as well as other similar elements.

**Building Setbacks**

Building setbacks from street right of ways within the PBOD shall be a minimum of 0' and the south and east frontages of the site will accommodate a 14' wide pedestrian walkway as shown on the sidewalk plans and sections on pages 5-10.

**Building Height**

The current PDD zoning of this site allows for a maximum building height of 132' or eight stories. We are proposing to further limit the maximum building height within the PBOD overlay to 120' measured in accordance with the City of Raleigh code of ordinance. It is also important to note that the relationship of the site to the residential property to the south is greatly mitigated by the fact that Edwards Mill Road rises to 25' above the site along this frontage.

**Parking**

The project will provide both on-street and off-street parking. Parking will be provided through a combination of both surface and structured parking. It is anticipated that the majority of the parking within the Crabtree Place PBOD will be contained in multi-level structures. The project will meet or exceed the minimum parking requirements of the City of Raleigh. Any surface parking (other than drop-off, delivery and temporary parking areas) visible from a public street will be screened from view in accordance with City standards. Bicycle parking will be provided at a rate of 1/20 car spaces unless a higher standard is required by the Code and will be located within the parking structures or near the main entrances to the structure.

Parking Location Diagram

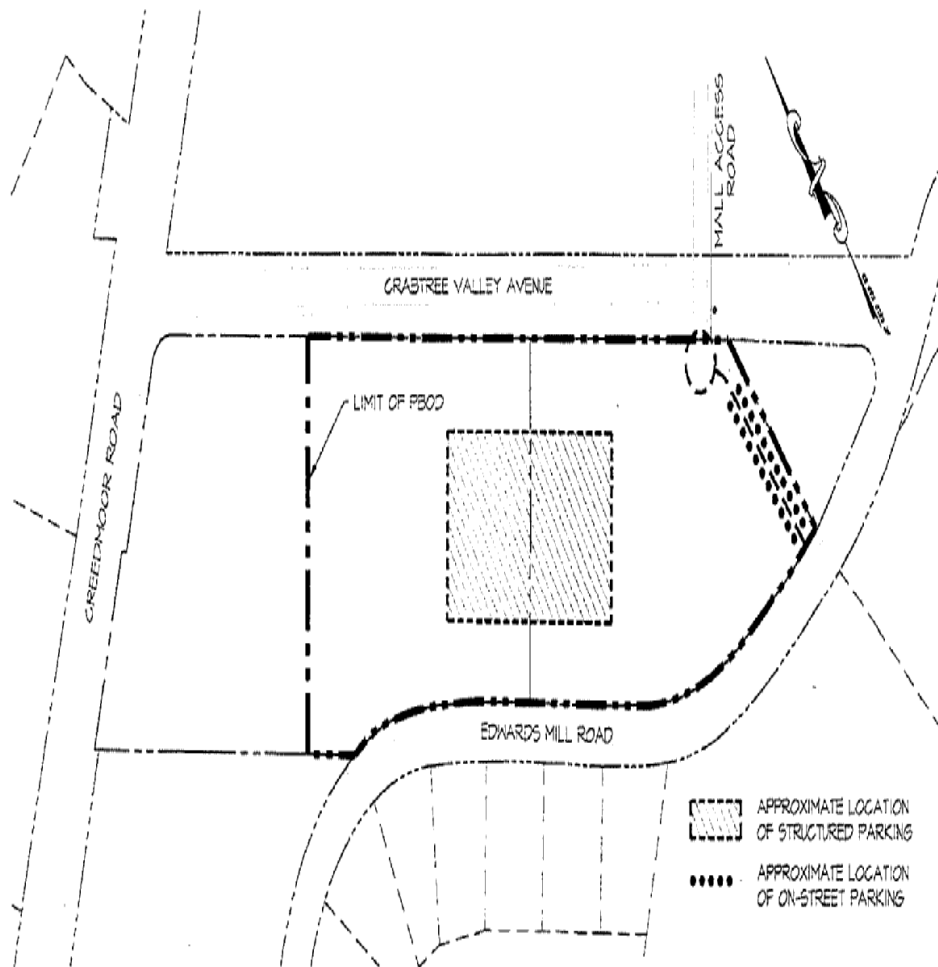

*Note: The actual location of the "Crabtree Valley Mall Connector Road" and associated on-street parking shown on pages 4 and 16 of this Streetscape and Parking Plan will be established at the time of site plan approval*

**Proposed Street Tree Palette**

Street trees will be installed per the streetscape plan at the time of development of the parcels at the public right of ways prior to the issuance of a certificate of occupancy for the development of the parcel. Trees will be installed at a minimum size of 3" caliper. Alternate similar street tree species may be substituted at the time of site plan as approved by staff to accommodate availability of species and direction from the City of Raleigh urban forester.

**Japanese Zelkova**

(*Zelkova serrata*)

Shape: Urn Shaped

Foliage: Green with sawtooth margins

Fall Color: Yellow to dark red



**Chinese Pistache**

(*Pistacia Chinensis*)

Shape: Oval

Foliage: Dark green leaflets

Fall Color: Orange to red





**Columnar European Hornbeam**

(*Carpinus betulus fastigiata*)

Shape: Dense pyramidal form

Foliage: 2-5" clean leaves

Fall Color: Yellow to dark red



**Willow Oak**

(*Quercus phellos*)

Shape: Oval to spreading

Foliage: Long willow-like thin leaves

Fall Color: Yellow or russet red



**Tree Grates**

Manufacturer: Neenah foundry Products  
Specification: Adirondack Collection  
(or approved equal)

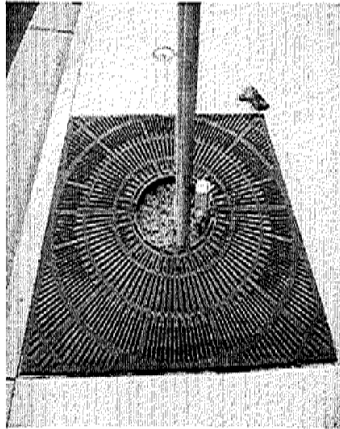

**Tree Planting Detail**

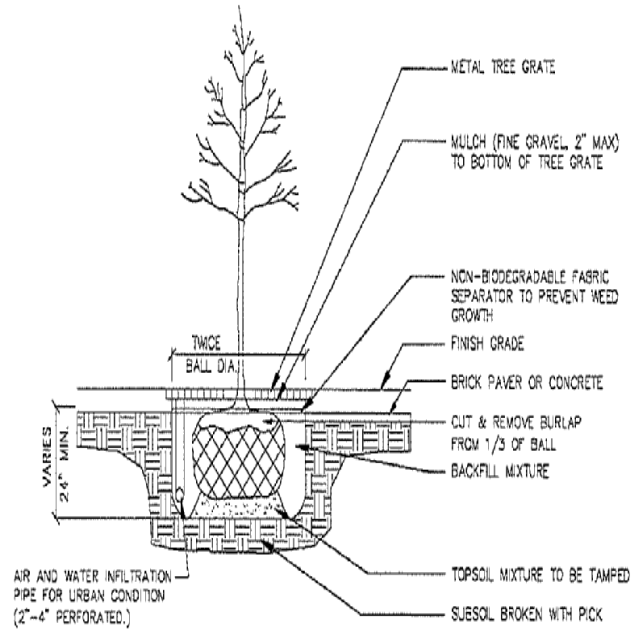

**Benches**

Manufacturer: Landscape Forms  
Specification: Austin Series bench with arms  
(or approved equal)

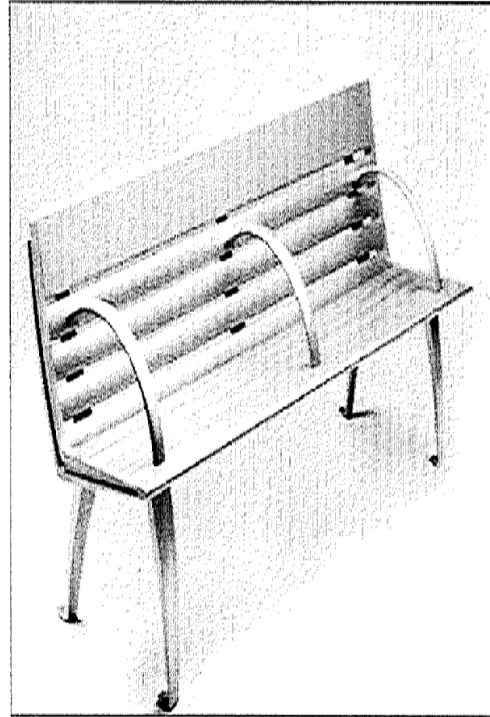

**Trash Receptacles**

Manufacturer: Landscape Forms  
Specification: Austin Series litter receptacle  
(or approved equal)

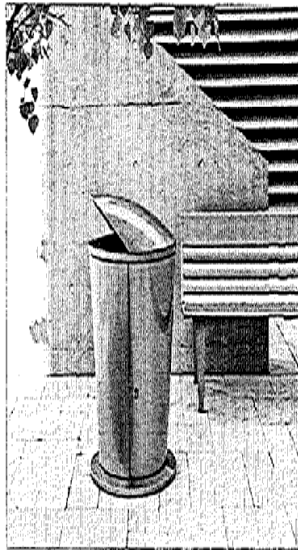

**Bike Racks**

Manufacturer: Landscape Forms  
Specification: Bola Series bike rack  
(or approved equal)

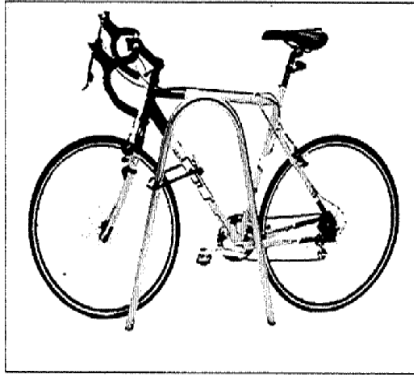

*Note: Certain items are specified in this Plan with the phrase "(or approved equal)." At the time of site plan approval, for these items staff may allow a substitution of another manufacturer or design upon a determination that the item substituted is of equivalent quality and function.*

Appendix – City Code Section 10-2055 – Pedestrian Business Overlay District

2-9-11

§ 10-2054

RALEIGH CITY CODE

8/19

Front yard setback: Minimum of ten (10) feet; maximum of twenty-five (25) feet.

Side yard setback: Minimum of zero (0) feet when minimum building separation is met.

Building separation: Minimum of ten (10) feet.

Maximum building height: Thirty-five (35) feet.

(Ord. No. 2008-428-TC-313, §2, TC-4-08, 7-1-08; Ord. No. 2010-711-TC-336, §§1-3, TC-7-10, 8-3-10)

Sec. 10-2055.

**PEDESTRIAN BUSINESS OVERLAY DISTRICT.**

(a) Approval.

If the use requires a *site plan*, as set forth in §10-2132.2, approval of a *site plan* is required by either the administrative staff, the Planning Commission, or the City Council; see §§10-2132.2(b) and (c). If the use requires a *plot plan*, as set forth in §10-2132.1, administrative approval is required. The required *site plan* is to be reviewed based on the procedures and standards contained in §10-2132.2(c) and (d).

(Ord. No. 1992-111-TC-42, §20, TC-19-92, 12-8-92; Ord. No. 1997-137-TC-153, §31, TC-18-96, 6-17-97; Ord. No. 2010-706-TC-331, §10, TC-1-10, 2-16-10)

(b) Permitted Uses.

Subject to the provisions of §10-2055 and other overlay districts, all general uses, conditional uses and special uses that are allowed in the underlying district by the Schedule of Permitted Uses in Zoning Districts §10-2071 are allowed in the Pedestrian Business Overlay District.

Following the approval of a *site plan* by the City Council, in accordance with §10-2051(d)(1), additional residential density, conversions of *building(s)* to *dwelling(s)*, reductions *net lot area* for *dwellings*, *dwellings* and *lodging units* with two (2) burner cook tops, and housing within the underlying industrial zoning districts are all permitted.

(Ord. No. 1992-88-TC-401, §13, TC-4-92, 11-4-92; Ord. No. 1997-137-TC-153, §35, TC-18-96, 6-17-97; Ord. No. 2007-262-TC-302, §10, TC-2(A.2)-07, 7-10-07)

(c) Prohibited Uses.

Except for improvements made pursuant to Part 10 chapter 3 of this Code and *residences* allowed in Industrial districts by the special use permit authorized by this overlay district, any use not explicitly allowed by both the underlying district by the Schedule of Permitted Land Uses in Zoning Districts §10-2071 and subsection (b) above is prohibited. If a use is prohibited in either an overlay district or the underly-

ing district, that use is prohibited even if one (1) of these districts allows the use. The enumeration of expressly prohibited uses shall not be deemed exclusive or all-inclusive. Prohibited uses include:

- All uses prohibited in the underlying zoning district
- Improvements to the sides of *buildings* fronting on a *thoroughfare* or collector *streets* to *street* rights-of-way except in conformance with the terms, conditions, plans, and provisions of the Streetscape Plan or Streetscape and Parking Plan unless approved by the Board of Adjustment in accordance with §10-2146.3(a)(7)
- Improvements to *street* rights-of-way except in conformance with the terms, conditions, plans, and provisions of the Streetscape Plan or Streetscape and Parking Plan unless approved by the Board of Adjustment in accordance with §10-2146.3(a)(7)

- *Vehicular display areas*

(Ord. No. 1992-88-TC-401, §10, TC-4-92, 11-4-92; Ord. No. 2000-740-TC-190, TC-1-99, §1, 2-18-00; Ord. No. 2004-596-TC-245, §3, TC-14-03, 4-6-04)

(d) Area, Density, Bulk, Yard, and Height Requirements.

(1) Area, density, and bulk.

- a. The required minimum *net lot area* for any *dwelling unit* and *equivalent dwelling unit* is that of the underlying zoning district unless a *site plan* is approved in accordance with §10-2051(d).
- b. The maximum residential density per net acre is that of the underlying zoning district unless a *site plan* is approved in accordance with §10-2051(d).

All minimum *net lot areas* and residential densities shall be calculated in accordance with §10-2073(c) and are subject to the exceptions listed in §10-2073(d).

(Ord. No. 2005-932-TC-275, §10, TC-6-05, 11-15-05)

(2) Yard.

The minimum overlay district yard setbacks, unless otherwise required by this Code, are:

<i>front yard, corner lot side yard, and rear yard that adjoin a street right-of-way</i>	-0- provided widths of pedestrian ways required in the Overlay District are met
--	---

all other yards	same as underlying zoning district
-----------------	------------------------------------

**Ordinance (2011) 940ZC662  
September 6, 2011**

2-9-11

See §10-2075 for other *yard areas* required by this Code, method of calculating, exceptions and reductions to *yard areas*, and illustrations.  
Cross references: Required width of pedestrian ways §10-2055(e)(5)

**(3) Height.**

*Buildings* and structures may be constructed to any height established in the Streetscape Plan or Streetscape and Parking Plan. If the height regulations of the underlying district conflict with the height regulations of the Streetscape Plan or Streetscape and Parking Plan, the Plan shall control. Whenever the Streetscape Plan or Streetscape and Parking Plan fails to adopt height limitations, those of the underlying zoning district shall be applied to the property.

See §10-2075 for method of height calculation, exceptions, and illustrations.  
(Ord. No. 2000-740-TC-190, TC-1-99, §1, 2-18-00)

**(4) Required open space.**

For the purposes of this subsection, and subsection 10-2051(d)(1)c.6., above, "open space" shall include greenways and any common outdoor landscaped and recreation spaces (excluding vehicular surface areas), outdoor decks, roof gardens and other similar outdoor community space accessible to and available for use by all residents, employees and/or visitors of the development.

The minimum "open space" provided on the site shall be five (5) per cent of the total land area of the development, excluding dedicated rights-of-way unless density transfer is allowed from the right-of-way.

The minimum required open space area shall be required to conform to the following standards:

**a. Sidewalk widening.**

Where the property lies adjacent to a public street right-of-way with an existing sidewalk width of eighteen (18) or less feet, sidewalk widening shall be required based on the following:

<u>Existing walkway condition</u>	<u>Construct to a minimum of</u>
0—14 feet	14 feet
>14—18 feet	18 feet
>18 feet	No sidewalk construction required

Additional right-of-way dedication shall not be required to accommodate the sidewalk

widening set forth herein. However, for any sidewalk widening provided to comply with these minimum requirements and located on private property, the property owner shall be required to grant to the City a public access easement. The newly constructed sidewalk shall be of compatible paving materials with the public sidewalk and shall conform to any applicable adopted streetscape plan. The sidewalk widening shall occur along the entirety of the public street frontage with no permanent obstructions, other than those that may be required by the City Code and structural columns supporting overhangs or upper-story structures creating an arcade or recessed covered area in which case the columns shall be spaced a minimum of five (5) feet from both the building facade and the individual columns; and

**b. Courtyard, roof garden, dining, recreation space.**

One-half (1/2) of the required open space shall be in one (1) continuous part with a minimum length and width dimension of twenty (20) feet.

Street level open spaces proposed to meet the requirements of subsection (ii) above located adjacent to proposed sidewalk widening may utilize the portion of the proposed sidewalk located on private property to meet the minimum twenty (20) foot dimension stated above. In the event that required sidewalk widening located on private property represents greater than two and one-half (2 1/2) percent of the total land area of the development, the minimum percentage requirement established by subsection (ii) shall be reduced accordingly such that no more than five (5) per cent of the total land area of the development shall be required to be devoted to open space required by this §10-2051(e).

No open space shall be required for any of the following:

- Rehabilitation of buildings or portions of buildings to sixteen (16) or fewer dwelling units or congregate care or congregate living units, per building.
- Single family detached dwellings or duplex dwellings on their own lot, where "open space" equivalent to the greater of twenty (20) per cent of the area of the lot or four

2-9-11

hundred thirty-five and six-tenths (435.6) square feet per dwelling or rooming unit is provided.

For rehabilitation of buildings or portions of buildings for all other uses, the designated approving authority as specified by §10-2132.2(e) may approve an alternate method of compliance for the required open space. The approved alternate method of compliance may be less than five (5) per cent of the total land area of the development. Alternate methods of compliance include, but are not limited to, private balconies and decks, indoor recreation areas, meeting rooms and community space accessible to and available for use by the residents, employees and/or visitors.

The minimum open space required by this Code for developments located in a Pedestrian Business Overlay District may be reduced as part of the subdivision or site plan approved by the Planning Commission or the City Council in accordance with §10-2132.2 after a finding that such reduction in open space is in accordance with the general plans for the physical development of the City as embodied in the Comprehensive Plan and after a finding that the site plan complies with the procedures and standards of §10-2132.2(c) and (d).

Editor's note: Prior to December 1, 2007, all high density residential projects approved in accordance with §10-2051(d)(1) shall be required to provide the following minimum "open space" requirement: The minimum "open space" provided on the site shall be fifteen (15) per cent of the total land area of the development, excluding dedicated rights-of-way unless densely transfer is allowed from the right-of-way, but not to exceed four hundred thirty-five and six-tenths (435.6) square feet per unit; or in the case of *congregate care or congregate living structures*, not to exceed two hundred eighteen (218) square feet per dwelling or rooming unit. In no case shall less than ten (10) per cent of the total land area of the development, excluding dedicated rights-of-way unless densely transfer is allowed from that right-of-way, be devoted to common outdoor open space accessible to all residents.

Cross reference: Open space is required for any cluster unit development, congregate care structure or congregate living structure, group housing development, life care community, manufactured home park, multi-family dwelling development, residential unit ownership (condominiums) and townhouse development, Part 10, chapter 2, Article E. (Ord. No. 1992-88-TC-401, §24, TC-4-92, 11-4-92; Ord. No. 1997-137-TC-153, §36, TC-18-96, 6-17-97; Ord. No. 2008-450-TC-316, §4, TC-11-08, 9-2-08; Ord. No. 2010-706-TC-331, §§11, 12, TC-1-10, 2-16-10)

(e) Supplementary Regulations.

All uses and activities are also subject to Article H, overlay zoning districts, conditional use zoning districts, and supplementary regulations of Article E. Supplementary regulations include:

(1) Off-street parking.

The minimum number of off-street parking spaces required for commercial and recreational land uses shall be based upon the ratios and coordinating strategies recommended by the adopted Streetscape and Parking Plan for the subject area of the Overlay District subject to compliance with the construction improvements required by the Streetscape and Parking Plan. In no case shall a Streetscape and Parking Plan adopt parking strategies which are less restrictive than that specified below. Where a Streetscape Plan had previously been adopted, but no Streetscape and Parking Plan has been subsequently adopted, the minimum number of off-street parking spaces shall be the number of spaces required below subject to compliance with the construction improvements required by the Streetscape Plan.

Except for site plans approved pursuant to Section 10-2051(d)(1) or for projects in the Transit Orientated Development Overlay District, the minimum number of off-street parking spaces required for new structures, additions or expansions to existing structures or changes in use shall be one (1) space per four hundred (400) square feet of building floor area or the minimum number of parking spaces set forth in §10-2081(a), SCHEDULE OF OFF-STREET PARKING STANDARDS, whichever is less, with the exception of the following land uses:

- a. Projects with sixteen (16) or fewer dwelling units per building shall not be required to provide any off-street parking spaces for the dwelling units. Projects with seventeen (17) or more dwelling units per building shall not be required to provide off-street spaces for the first sixteen (16) dwelling units, but shall be required to provide at least one (1) off-street parking space per unit in excess of sixteen (16) units; with the exception that, units occupied by no more than two (2) residents not related by blood, marriage or adoption sixty-two (62) years and older shall provide a minimum of one-half (1/2) space per unit. For residential developments or the residential portion of a mixed-use development, no more than two (2) parking spaces per dwelling unit shall be located on the site. However, proposed expansions or modifications to existing developments with on-site parking shall be required to retain a minimum of one (1) on-site parking space devoted to persons with disabilities.



**Ordinance (2011) 940ZC662  
September 6, 2011**

2-9-11

- b. No parking shall be required for retail facilities located within existing uses; new structures, additions or expansions to existing structures or changes in use, all ten thousand (10,000) square feet or less; or, the first ten thousand (10,000) square feet of existing uses, new structures, additions or expansions to existing structures or changes in use, all greater than ten thousand (10,000) square feet. For purposes of this subsection, "retail facilities" means *retail sales-convenience, retail sales-personal services, food store-retail, recreational indoor use-commercial, retail banking; and eating establishments, bars, nightclubs, taverns and lounges* located no closer than one hundred (100) feet to a residential zoning district or located within one hundred (100) feet of a residential zoning district with hours of operation not extending past 11:00 p.m. However, proposed expansions or modifications to existing developments with on-site parking shall be required to retain a minimum of one (1) on-site parking space devoted to persons with disabilities.
- c. Parking requirements for *eating establishments, bars, nightclubs, taverns and lounges*

located within one hundred (100) feet of a residential zoning district with hours of operation extending past 11:00 p.m. shall be that specified by the adopted Streetscape and Parking Plan for commercial uses. Where a Streetscape Plan had previously been adopted, but no Streetscape and Parking Plan has been subsequently adopted, the minimum number of off-street parking spaces shall be one space for every one hundred (100) square feet floor area gross of building for public use or one space for every eight (8) seats, whichever is greater.

(Ord. No. 2000-740-TC-190, TC-1-99, §2, 2-13-00; Ord. No. 2008-350-TC-307, §3, TC-2(B)-07, 2-5-08)

(2) Vehicular parking areas.

No new vehicular parking areas, including additions to vehicular parking areas existing prior to the application of the Pedestrian Business Overlay District, shall be located in any portion of the site parallel to and adjoining a thoroughfare unless such vehicular parking areas are located behind the front wall of the principal building as viewed perpendicular to the recorded thoroughfare street right-of-way.

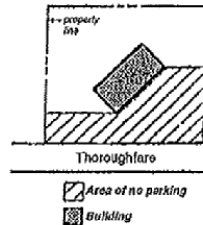

Diagram: No Parking Area Relative to Thoroughfare

Vehicular parking areas lawfully existing prior to the application of the Pedestrian Business Overlay District may be utilized by existing uses and buildings in the Overlay District. These vehicular parking areas shall be made to conform to the adopted Streetscape Plan or Streetscape and Parking Plan, the design standards of §10-2081(b), and the provisions for handicap spaces whenever those

buildings and uses that utilize these vehicular parking spaces undergo one (1) or more of the following:

- a. Expansions or additions that singularly or collectively exceed either twenty-five (25) per cent of the total floor area gross of the building or twenty-five (25) per cent of the total gross area occupied by the use where

10/2/C-87

Ordinance (2011) 940ZC662  
September 6, 2011

2-9-11

§ 10-2055

RALEIGH CITY CODE

8/10

there is no principal *building*. The per cent of expansion is to be determined with reference to the size and area of the *building* or use which existed at the time the Overlay District first became applicable to the *property*.

- b. Renovation or repair work which, during any one (1) calendar year exceeds twenty-five (25) per cent of the Wake County listed tax value.
- c. Change in use which results in a change in the type of Building Code occupancy as set forth in the North Carolina Building Code. (Ord. No. 2000-740-TC-190, TC-1-99, §3, 2-18-00)

(3) Landscape.

Landscaping shall be done in accordance with §10-2082, and all *street trees* shall be planted in accordance with the adopted Streetscape Plan or Streetscape and Parking Plan. (Ord. No. 2000-740-TC-190, TC-1-99, §3, 2-18-00)

(4) Signage.

See §10-2083 for *on-premise signs* and §10-2084 for *off-premise signs*. No sign shall be erected, altered, replaced, restored, or moved unless the change is in accordance with the Streetscape Plan or Streetscape and Parking Plan. (Ord. No. 2000-740-TC-190, TC-1-99, §3, 2-18-00)

(5) Pedestrian ways.

The minimum width of pedestrian ways from the curb to the *building* line for all new *buildings* and uses shall be eighteen (18) feet wide, unless the width of pedestrian ways for more than seventy-five (75) per cent of the linear frontage of pedestrian ways on the same side of the *street* as the new development, within a single block, are less than fourteen (14) feet. In such instances, the minimum pedestrian way shall be in accordance with §10-2055(d)(4) above.

All improvements to pedestrian ways shall be made in accordance with the adopted Streetscape Plan or Streetscape and Parking Plan. Upon adoption of a Streetscape and Parking Plan, alternatives to the aforementioned requirements for pedestrian ways may be established by the adopted Streetscape and Parking Plan. All improvements to pedestrian ways shall be made in accordance with the adopted Streetscape and Parking Plan whenever the *property* is developed using any of the less stringent standards of this Overlay District.

(Ord. No. 2000-740-TC-190, TC-1-99, §4, 2-18-00; Ord. No. 2008-450-TC-316, §5, TC-11-08, 9-2-08)

(6) Bicycle parking.

Bicycle parking spaces shall be provided for all new uses, new *buildings*, and for existing *buildings* and uses whenever those existing *buildings* and uses undergo any one (1) or more of the expansions, expenditures, or changes listed in subsections a. through c. of §10-2055(e)(2) above. Bicycle spaces shall be provided at a rate of at least one (1) bicycle space for every twenty (20) automobile spaces provided of five thousand (5,000) square feet of nonresidential floor area gross, whichever is greater. Bicycle parking facilities shall be located within easy access from the *street* right-of-way, and shall be designed in accordance with the Streetscape Plan or Streetscape and Parking Plan. (Ord. No. 1992-111-TC-42, §21, TC-19-92, 12-8-92; Ord. No. 2000-740-TC-190, TC-1-99, §5, 2-18-00; Ord. No. 2008-350-TC-307, §4, TC-2(B)-07, 2-3-08)

(7) Exterior building walls.

Fifteen (15) linear feet shall be the maximum length of a "blank exterior *building* wall plane" facing a *thoroughfare* for any new *building* and for any existing *building* that is either replaced or undergoes one (1) or more of the expansions, expenditures, or changes listed in subsections a. through c. of §10-2055(e)(2) above. All other existing *buildings* shall not increase the amount of "blank exterior *building* wall plane" beyond that which is allowed for new *buildings*. A "blank exterior *building* wall plane" is any wall unbroken to the height of nine (9) feet by any one (1) or more of the following:

- a. A public doorway made of transparent materials.
- b. A doorway made of opaque materials and recessed at least three (3) feet.
- c. A stairway directly available at *street* level to the public, but not fire escapes or false stairways.
- d. A window or fenestration opening in keeping with the architectural character of the surrounding area of at least twelve (12) square feet in area and no more than four (4) feet above the sidewalk at its lowest point.

(Ord. No. 2000-740-TC-190, TC-1-99, §6, 2-18-00)

(8) Thoroughfare driveway widths.

The maximum length of any curb cut made to a *thoroughfare* after application of the Pedestrian

10/2/C-88

Ordinance (2011) 940ZC662  
September 6, 2011

2-9-11

8/10

PLANNING AND DEVELOPMENT

§ 10-2055

Business Overlay District *shall* be fifteen (15) feet for one-way driveways and twenty-five (25) feet for two-way driveways or joint driveways.

(9) "Streetscape Plan" and "Streetscape and Parking Plan."

No improvement to *street* rights-of-way, to *vehicular surface areas* and to the sides of any building that face a *thoroughfare* or a collector *street* shall be made within a Pedestrian Business Overlay District except in conformity with the adopted Streetscape Plan or Streetscape and Parking Plan. All additions, changes, expansions, and alterations to such existing structures must comply with the regulations of the Streetscape Plan or Streetscape and Parking Plan unless the Board of Adjustment in accordance with §10-2146.3(a)(7) approves the addition, change, expansion, or alteration, as if the structure were made nonconforming by the Overlay District. Improvements to *thoroughfare* rights-of-way that are part of the Streetscape Plan or Streetscape and Parking Plan *shall* be installed whenever the *properties* that adjoin said rights-of-way acquire new *buildings*, new uses, or undergo expansions, expenditures, or changes listed in subsections a. through c. of §10-2055(e)(2) above. These required improvements to *street* rights-of-way *shall* be completed prior to the issuance of a *building occupancy certificate*.

(Ord. No. 2000-740-TC-190, TC-1-99, §7, 2-18-00; Ord. No. 2003-373-TC-231, §5, TC-23-02, 2-4-03)

(10) Existing structures and lots.

A structure existing at the time that the Pedestrian Business Overlay District is first applied to the *property* shall not be deemed a *zoning nonconformity* solely because of this Overlay District. All additions, changes, expansions, and alterations must comply with the Streetscape Plan or Streetscape and Parking Plan, unless the Board of Adjustment in accordance with §10-2146.3(a)(7) approves the addition, change, expansion, or alteration as if the structure or use were made nonconforming by the Overlay District.

(Ord. No. 2000-740-TC-190, TC-1-99, §7, 2-18-00; Ord. No. 2003-373-TC-231, §5, TC-23-02, 2-4-03)

(f) Designation of a Pedestrian Business Overlay District and Adoption of a Streetscape and Parking Plan.

(1) Locational guidelines.

The general characteristics desired of land placed in the Pedestrian Business Overlay District are the following:

- a. It consists primarily of *retail uses* as defined in §10-8002.
- b. It comprises at least one (1) side of one (1) block, including any existing Pedestrian Business Overlay District.
- c. It draws pedestrian patronage to it from an adjoining employment center or a residential neighborhood.
- d. It is an area with one (1) or more of the following characteristics:
  1. It was developed prior to the application of off-*street* parking requirements; or
  2. It possesses unifying distinctive *built environmental characteristics* that create an identifiable pedestrian setting, character or association;
  3. It is an expansion of an existing Pedestrian Business Overlay District.

(2) Streetscape and Parking Plan.

A Streetscape and Parking Plan *shall* be completed for any area zoned a Pedestrian Business Overlay District. No Streetscape and Parking Plan *shall* be approved by the *City Council* until after a recommendation thereon has been made by the Appearance Commission. At least ten (10) days before the Planning Commission makes its recommendation to the *City Council*, a copy of the Streetscape and Parking Plan *shall* be mailed to *property owners* within the proposed Pedestrian Business Overlay District. The Streetscape and Parking Plan *shall* be approved prior to or in conjunction with the zoning of any area as a Pedestrian Business Overlay District. The Streetscape and Parking Plan records designs and policies concerning the character and function of the area, and *shall* be at least one (1) block long on both sides of the block. The Streetscape and Parking Plan *shall* include at least these elements:

- a. Sidewalk building materials and typical construction detail, showing the layout pattern, underlayment, and curb design
- b. *Street* furniture types, including sidewalk light fixtures, benches, garbage receptacles, tree guards and grates, and other furnishings within the public right-of-way
- c. Canopy or awning height above sidewalk, construction type, materials, and size

10/2/C-88.1

2-9-11

- d. *Street tree species, planting detail for street trees (showing drainage, planting hole design, tree support and protection), and location of street trees in the right-of-way*
- e. *Pedestrian crosswalk location*
- f. *Utility line location, either under the sidewalk or above it in the public right-of-way*
- g. *A maintenance plan for the care of streetscape improvements to the public right-of-way*
- h. *Signs, types, sizes, graphics, materials and colors*
- i. *Location and arrangement of public off-site and off-street parking lots and a plan for providing adequate public off-site and off-street vehicle and bicycle parking for the Overlay District.*
- j. *Assessment of the extent to which minimum off-street parking requirements may be reduced for commercial or recreational uses.*
- k. *Width of pedestrian ways from the curb(s) to the building line.*

l. **Maximum height limitations.**

*Editor's Note: Prior to February 23, 2000 (effective date of Ordinance No. 2000-740-TC-190, TC-1-99), a Streetscape Plan (not a Streetscape and Parking Plan) was required to be approved in conjunction with a Pedestrian Business Overlay District. A Streetscape Plan did not include subparagraph "l." through "l." above.*

*(Ord. No. 1986-856-TC-274, §3, TC-11-86, 9-16-88; Ord. No. 1987-29-TC-294, §10, TC-14-87, 12-1-87; Ord. No. 1989-438-TC-344, §1, TC-11-89, 10-3-89; Ord. No. 2000-740-TC-190, TC-1-99, §8, 2-18-00)*

**Sec. 10-2056.  
RESERVOIR WATERSHED PROTECTION AREA  
OVERLAY DISTRICT.**

**(a) Approval.**

If the use requires a *site plan* as set forth in §10-2132.2, approval of a *site plan* is required by either the administrative staff, the Planning Commission, or the *City Council*; see §10-2132.2(b) and (c). If the use requires a *plot plan*, as set forth in §10-2132.1, administrative approval is required.

*(Ord. No. 1997-137-TC-153, §2, TC-18-96, 1-14-97)*

**(b) Definitions.**

*Primary water supply watershed protection area.* The area in a Reservoir Watershed Protection Area Overlay District or an Urban Water Supply Watershed Protection Area Overlay District between the intake or mean high water level of the reservoir and the *secondary*

*water supply watershed protection area.* To protect the watershed, special standards for *impervious surface coverage*; uses, *natural resource buffer yards* and *lot sizes* are applied. *Primary water supply watershed protection areas* are delineated on the Official Zoning Maps and reflected in the *Comprehensive Plan*.

*Secondary water supply watershed protection area.* The area in a Reservoir Watershed Protection Overlay District or an Urban Water Supply Watershed Protection Area Overlay District between the *primary water supply watershed protection area* and surrounding *properties*. To provide a protective transition between the *primary water supply watershed protection area* and the surrounding *properties*, special standards for *impervious surface coverage*, uses, and *natural resource buffer yards* are applied. *Secondary water supply watershed protection areas* are delineated on the Official Zoning Maps, and reflected in the *Comprehensive Plan*.

*(Ord. No. 2005-817-TC-267, §3, TC-7-05, 4-19-05)*

**(c) Permitted Uses.**

Subject to the provisions of §10-2056 and other overlay districts, all general uses, conditional uses, and special uses that are allowed in the underlying zoning district by the Schedule of Permitted Uses in Zoning Districts, §10-2071, are allowed in the Reservoir Watershed Protection Area Overlay District. In the *primary water supply watershed protection area* of this Overlay District, the *following* uses are only allowed (even if the underlying zoning district classifies the use as a Board of Adjustment special use or a general use) when a special use permit is issued by the *City Council* in accordance with §10-2145 or by the Board of Adjustment if the *City* is the applicant:

- *Recreation use restricted to membership - not for profit in a residential district, Agricultural Productive, or Residential Business District.*
- *Recreation use of a governmental entity.*
- *Not for profit recreational camps.*

*(Ord. No. 2005-817-TC-267, §4, TC-7-05, 4-19-05)*

**(d) Prohibited Uses.**

Except for improvements made pursuant to Part 10 chapter 3 of this Code, any use not explicitly allowed in the underlying district by either the Schedule of Permitted Land Uses in Zoning District §10-2071 or subsection (c) above is prohibited in the Reservoir Watershed Protected Area Overlay District. If a use is prohibited in either an overlay district or the underlying district, that use is prohibited even if one (1) of

**Ordinance (2011) 940ZC662**  
**September 6, 2011**