

CERTIFICATE OF APPROPRIATENESS PLACARD

for Raleigh Historic Resources

218 S BLOUNT STREET

Address

MOORE SQUARE

Historic District

Historic Property

184-16-MW

Certificate Number

11-17-2016

Date of Issue

05-17-2017

Expiration Date

Project Description:

- Install emergency egress lights; c
- Change paint color for previously approved COA 014-16-MW

This card must be kept pasted in a location within public view until all phases of the described project are complete. The work must conform with the code of the City of Raleigh and laws of the state of North Carolina. When your project is complete, you are required to ask for a final zoning inspection in a historic district area. Telephone the RHDC office at 832-7238 and commission staff will coordinate the inspection with the Inspections Department. If you do not call for this final inspection, your Certificate of Appropriateness is null and void.

Signature _____
Raleigh Historic Development Commission

Pending the resolution of appeals, commencement of work is at your own risk.



Planning & Development

Development Services
 Customer Service Center
 One Exchange Plaza
 1 Exchange Plaza, Suite 400
 Raleigh, North Carolina 27601
 Phone 919-996-2495
 eFax 919-996-1831

Raleigh Historic Development Commission – Certificate of Appropriateness (COA) Application



- Minor Work (staff review) – 1 copy
- Major Work (COA Committee review) – 13 copies
- Most Major Work Applications
- Additions Greater than 25% of Building Square Footage
- New Buildings
- Demo of Contributing Historic Resource
- Post Approval Re-review of Conditions of Approval

For Office Use Only

Transaction # 493189

File # K84-16-UW

Fee \$29

Amt Paid \$29

Check # CC

Rec'd Date ACH

Rec'd By 11/1/16

• If completing by hand, please use **BLACK INK**. Do not use blue, red, any other color, or pencil as these do not photocopy.

Property Street Address **218 South Blount Street**

Historic District **Moore Square HOD**

Historic Property/Landmark name (if applicable) **N/A**

Owner's Name **PPAS Properties LLC - Pete Pagano**

Lot size **0.18 acres** (width in feet) **73** (depth in feet) **110**

For applications that require review by the COA Committee (Major Work), provide addressed, stamped envelopes to owners of all properties within 100 feet (i.e. both sides, in front (across the street), and behind the property) not including the width of public streets or alleys:

Property Address	Property Address

I understand that all applications that require review by the commission's Certificate of Appropriateness Committee must be submitted by 4:00 p.m. on the application deadline; otherwise, consideration will be delayed until the following committee meeting. An incomplete application will not be accepted.

Type or print the following:

Applicant **Nicole Alvarez**

Mailing Address **Clearscapes: 311 W Martin Street, Suite 200**

City **Raleigh** State **NC** Zip Code **27601**

Date **11/1/2016** Daytime Phone **919-821-2775**

Email Address **nalvarez@clearscapes.com**

Signature of Applicant _____

Minor Work Approval (office use only)

Upon being signed and dated below by the Planning Director or designee, this application becomes the Minor Work Certificate of Appropriateness. It is valid until 5/17/17. Please post the enclosed placard form of the certificate as indicated at the bottom of the card. Issuance of a Minor Work Certificate shall not relieve the applicant, contractor, tenant, or property owner from obtaining any other permit required by City Code or any law. Minor work projects not approved by staff will be forwarded to the Certificate of Appropriateness Committee for review at the next scheduled meeting.

Signature  Date 11/17/16

Project Categories (check all that apply):

Exterior Alteration

Addition

New Construction

Demolition

Will you be applying for state or federal rehabilitation tax credits for this project?

Yes

No

(Office Use Only)

Type of Work _____

48, 49

Design Guidelines Please cite the applicable sections of the design guidelines (www.rhdc.org).

Section/Page	Topic	Brief Description of Work
2.7/20-21	Lighting	Install new emergency egress lighting
3.11/48-49	Life-safety	Install new emergency egress lighting

	TO BE COMPLETED BY APPLICANT		TO BE COMPLETED BY CITY STAFF		
	YES	N/A	YES	NO	N/A
<p>Attach 8-1/2 " x 11" sheets with written descriptions and drawings, photographs, and other graphic information necessary to completely describe the project. Use the checklist below to be sure your application is complete.</p> <p>Minor Work (staff review) – 1 copy</p> <p>Major Work (COA Committee review) – 13 copies</p>			✓		
1. Written description. Describe clearly and in detail the nature of your project. Include exact dimensions for materials to be used (e.g. width of siding, window trim, etc.)	<input checked="" type="checkbox"/>		✓		
2. Description of materials (Provide samples, if appropriate)	<input checked="" type="checkbox"/>		✓		
3. Photographs of existing conditions are required.	<input checked="" type="checkbox"/>		✓		
4. Paint Schedule (if applicable)	<input type="checkbox"/>	<input checked="" type="checkbox"/>			✓
5. Plot plan (if applicable). A plot plan showing relationship of buildings, additions, sidewalks, drives, trees, property lines, etc., must be provided if your project includes any addition, demolition, fences/walls, or other landscape work. Show accurate measurements. You may also use a copy of the survey you received when you bought your property. Revise the copy as needed to show existing conditions and your proposed work.	<input type="checkbox"/>	<input checked="" type="checkbox"/>			✓
6. Drawings showing proposed work <ul style="list-style-type: none"> <input type="checkbox"/> Plan drawings <input type="checkbox"/> Elevation drawings showing the new façade(s). <input type="checkbox"/> Dimensions shown on drawings and/or graphic scale. <input type="checkbox"/> 8-1/2" x 11" reductions of full-size drawings. If reduced size is so small as to be illegible, make 8-1/2" x 11" snap shots of individual drawings on the big sheet. 	<input checked="" type="checkbox"/>	<input type="checkbox"/>	✓		
7. Stamped envelopes addressed to all property owners within 100 feet of property not counting the width of public streets and alleys. (Required for Major Work)	<input type="checkbox"/>	<input checked="" type="checkbox"/>			✓
8. Fee (See Development Fee Schedule)	<input checked="" type="checkbox"/>	✓			

Minor Work Application

Plenty Restaurant Renovation 218 S Blount St.

November 1, 2016

Description:

This application is for new emergency egress lighting on the façade of Plenty Restaurant, located within the Moore Square Historic Overlay District.

A COA was issued for all other façade work on 1/27/2016, certificate number 014-16-MW.

The 2 proposed light fixtures would be centered over each double-door entry. They will be mounted at 13'-0" AFF to provide adequate egress lighting, and to provide a spatial buffer from the signage area. See attached drawings and photos for more information.

The specification sheet is attached for light fixture selection: EELP Model DEM-LED. The finish will be black to coordinate with other secondary façade elements including the concrete bases, gutters, and existing lights.

Please see attached pictures, drawings, and specifications for more details and dimensions.

COA 014-16-MW - Revision

Plenty Restaurant Renovation
218 S Blount St.

November 10, 2016

All white paint noted on façade of original application was Sherwin Williams SW 7557 Summer White.
We would like to revise this white paint selection to Sherwin Williams SW 6070 Heron Plume. See attached paint chips.

Approved color change
from COA 014-16-MW
TGT



Former Selection:
SW 7557 Summer White



New Selection:
SW 6070 Heron Plume



BIDA MANDA RESTAURANT
222 S. BLOUNT STREET

5 EXAMPLE PHOTO
NTS



4 EXISTING PHOTO
NTS

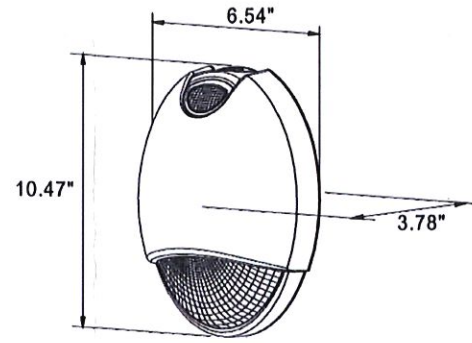

EELP
MODEL: DEM-LED
COLOR: BLACK

3 LIGHT FIXTURE SELECTION
NTS



2 ENLARGED ELEVATION
Scale: 1/4" = 1'-0"



OTHER FACADE IMPROVEMENTS APPROVED WITH
COA CERTIFICATE NUMBER: 014-16-MW

1 PROPOSED ELEVATION
Scale: 1/8" = 1'-0"

Plenty

Restaurant Renovation
218 S Blount St.
Raleigh, NC 27601

DATE: 20161101
DRAWN: NNA
CHECKED: FWB
FILENAME: PLENTY PLANS
PROJECT NO: 20150260
PRINTING:

Elevations

Existing + Proposed